

Installation Manual  
(Translation of original  
language)

EN



**innova**

N420530A - Rev.03 - 07/24

# FÄRNA

ECA044 - EWA044 - EEB749 - EFB749 -  
EGB749 - B10042 - B4V042 - B3V151

---

*First of all, we would like to thank you for having chosen a device of our production.*

*We are sure you will be happy with it because it represents the state of the art in the technology of home air conditioning.*

*By following the suggestions contained in this manual, the product you have purchased will operate without problems giving you optimum room temperatures with minimum energy costs.*

*INNOVA S.r.l.*

## **Conformity**

Refer to the Installation Manual of the paired unit.

## **Markings**



# TABLE OF CONTENTS

<b>1</b>	<b>Coding</b> .....	<u><i>p. 6</i></u>
1.1	Coding accessories .....	<u><i>p. 6</i></u>
<b>2</b>	<b>General information</b> .....	<u><i>p. 7</i></u>
2.1	<b>About the manual.</b> .....	<u><i>p. 7</i></u>
2.1.1	Editorial pictograms .....	<u><i>p. 7</i></u>
2.1.2	Pictograms on the product .....	<u><i>p. 7</i></u>
2.1.3	Recipients .....	<u><i>p. 7</i></u>
2.1.4	Manual organisation .....	<u><i>p. 7</i></u>
2.2	<b>General warnings</b> .....	<u><i>p. 8</i></u>
2.3	<b>Basic rules of security</b> .....	<u><i>p. 8</i></u>
2.4	<b>Disposal.</b> .....	<u><i>p. 9</i></u>
<b>3</b>	<b>Preparation for touchpad connection</b> .....	<u><i>p. 10</i></u>
3.1	<b>Preliminary warnings.</b> .....	<u><i>p. 10</i></u>
3.2	<b>Preparation for command connection.</b> .....	<u><i>p. 10</i></u>
	Accompanying material .....	<u><i>p. 10</i></u>
3.2.1	Preliminary warnings .....	<u><i>p. 10</i></u>
3.2.2	Device preparation .....	<u><i>p. 11</i></u>
3.2.3	Installation of electrical connection box .....	<u><i>p. 12</i></u>
3.2.4	Completed assembly .....	<u><i>p. 13</i></u>
3.2.5	Access to the terminal block .....	<u><i>p. 14</i></u>
<b>4</b>	<b>Touchpad and remote control Code ECA044</b> .....	<u><i>p. 15</i></u>
4.1	<b>Interface</b> .....	<u><i>p. 15</i></u>
4.2	<b>Description.</b> .....	<u><i>p. 15</i></u>
4.3	<b>Electronic board ECA044</b> .....	<u><i>p. 16</i></u>
4.4	<b>Connections</b> .....	<u><i>p. 16</i></u>
4.4.1	Presence contact CP .....	<u><i>p. 16</i></u>
4.5	<b>Functions.</b> .....	<u><i>p. 17</i></u>
4.5.1	Basic menu .....	<u><i>p. 17</i></u>
4.5.2	Advanced Menu .....	<u><i>p. 17</i></u>
4.5.3	Error signals .....	<u><i>p. 18</i></u>
4.5.4	Visualization of alarms on display .....	<u><i>p. 18</i></u>
<b>5</b>	<b>Touchpad Code EWA044</b> .....	<u><i>p. 20</i></u>
5.1	<b>Interface</b> .....	<u><i>p. 20</i></u>
5.2	<b>Description.</b> .....	<u><i>p. 20</i></u>
5.3	<b>Electronic board EWA044.</b> .....	<u><i>p. 21</i></u>
5.4	<b>Connections</b> .....	<u><i>p. 22</i></u>
5.4.1	Presence contact CP .....	<u><i>p. 22</i></u>
5.5	<b>Functions.</b> .....	<u><i>p. 22</i></u>

5.5.1	Basic menu . . . . .	<u>p. 22</u>
5.5.2	Advanced Menu . . . . .	<u>p. 23</u>
5.5.3	Error signals . . . . .	<u>p. 23</u>
5.5.4	Visualization of alarms on display . . . . .	<u>p. 24</u>
<b>6</b>	<b>Preparation for connecting M7 series wall controls . . . . .</b>	<b><u>p. 25</u></b>
<b>6.1</b>	<b>Preliminary warnings. . . . .</b>	<b><u>p. 25</u></b>
<b>6.2</b>	<b>Preparation for command connection . . . . .</b>	<b><u>p. 25</u></b>
	Accompanying material . . . . .	<u>p. 25</u>
6.2.1	Preliminary warnings . . . . .	<u>p. 25</u>
6.2.2	Device preparation . . . . .	<u>p. 26</u>
6.2.3	Installation of electrical connection box . . . . .	<u>p. 27</u>
6.2.4	Completed assembly . . . . .	<u>p. 28</u>
6.2.5	Access to the terminal block . . . . .	<u>p. 28</u>
<b>7</b>	<b>M7 series control Code EEB749 . . . . .</b>	<b><u>p. 29</u></b>
<b>7.1</b>	<b>Interface . . . . .</b>	<b><u>p. 29</u></b>
<b>7.2</b>	<b>Installation. . . . .</b>	<b><u>p. 29</u></b>
7.2.1	Description . . . . .	<u>p. 29</u>
7.2.2	Mounting . . . . .	<u>p. 29</u>
<b>7.3</b>	<b>Single connection diagram . . . . .</b>	<b><u>p. 31</u></b>
<b>7.4</b>	<b>Multiple connection diagram . . . . .</b>	<b><u>p. 32</u></b>
<b>7.5</b>	<b>Connections . . . . .</b>	<b><u>p. 33</u></b>
7.5.1	Preliminary warnings . . . . .	<u>p. 33</u>
7.5.2	Control Panel . . . . .	<u>p. 33</u>
7.5.3	Presence contact CP . . . . .	<u>p. 33</u>
7.5.4	RS485 Serial Connection. . . . .	<u>p. 34</u>
<b>7.6</b>	<b>Functions. . . . .</b>	<b><u>p. 34</u></b>
7.6.1	Basic menu . . . . .	<u>p. 34</u>
7.6.2	Advanced Menu . . . . .	<u>p. 35</u>
7.6.3	Pairing of control and unit . . . . .	<u>p. 36</u>
7.6.4	Error signals . . . . .	<u>p. 37</u>
7.6.5	Alarm display on wall control panel . . . . .	<u>p. 37</u>
<b>8</b>	<b>M7 series control Part No. EFB749 . . . . .</b>	<b><u>p. 38</u></b>
<b>8.1</b>	<b>Interface . . . . .</b>	<b><u>p. 38</u></b>
<b>8.2</b>	<b>Installation. . . . .</b>	<b><u>p. 38</u></b>
8.2.1	Description . . . . .	<u>p. 38</u>
8.2.2	Mounting . . . . .	<u>p. 38</u>
<b>8.3</b>	<b>Single connection diagram . . . . .</b>	<b><u>p. 40</u></b>
<b>8.4</b>	<b>Multiple connection diagram . . . . .</b>	<b><u>p. 41</u></b>
<b>8.5</b>	<b>Connections . . . . .</b>	<b><u>p. 42</u></b>
8.5.1	Preliminary warnings . . . . .	<u>p. 42</u>
8.5.2	Control Panel . . . . .	<u>p. 42</u>
8.5.3	Presence contact CP . . . . .	<u>p. 42</u>
8.5.4	RS485 Serial Connection. . . . .	<u>p. 43</u>
<b>8.6</b>	<b>Functions. . . . .</b>	<b><u>p. 43</u></b>
8.6.1	Basic menu . . . . .	<u>p. 43</u>
8.6.2	Advanced Menu . . . . .	<u>p. 44</u>







8.6.3	Pairing of control and unit . . . . .	<u>p. 45</u>
8.6.4	Error signals . . . . .	<u>p. 46</u>
8.6.5	Alarm display on wall control panel . . . . .	<u>p. 47</u>
<b>9</b>	<b>M7 series control Code EGB749 . . . . .</b>	<b><u>p. 48</u></b>
<b>9.1</b>	<b>Interface . . . . .</b>	<b><u>p. 48</u></b>
<b>9.2</b>	<b>Installation . . . . .</b>	<b><u>p. 48</u></b>
9.2.1	Description . . . . .	<u>p. 48</u>
9.2.2	Mounting . . . . .	<u>p. 48</u>
<b>9.3</b>	<b>Single connection diagram . . . . .</b>	<b><u>p. 50</u></b>
<b>9.4</b>	<b>Multiple connection diagram . . . . .</b>	<b><u>p. 51</u></b>
<b>9.5</b>	<b>Connections . . . . .</b>	<b><u>p. 52</u></b>
9.5.1	Preliminary warnings . . . . .	<u>p. 52</u>
9.5.2	Control Panel . . . . .	<u>p. 52</u>
9.5.3	Presence contact CP . . . . .	<u>p. 52</u>
9.5.4	Bluetooth connection . . . . .	<u>p. 53</u>
<b>9.6</b>	<b>Functions . . . . .</b>	<b><u>p. 53</u></b>
9.6.1	Basic menu . . . . .	<u>p. 53</u>
9.6.2	Advanced Menu . . . . .	<u>p. 54</u>
9.6.3	Pairing of control and unit . . . . .	<u>p. 55</u>
9.6.4	Error signals . . . . .	<u>p. 56</u>
9.6.5	Visualization of alarms on display . . . . .	<u>p. 56</u>
<b>10</b>	<b>Onboard electronic board B4V042 + wall control B3V151 . . . . .</b>	<b><u>p. 57</u></b>
<b>10.1</b>	<b>Onboard electronic board Code B4V042 + wall control Code B3V151 . . . . .</b>	<b><u>p. 57</u></b>
10.1.1	Interface . . . . .	<u>p. 57</u>
10.1.2	Description . . . . .	<u>p. 57</u>
10.1.3	Connection diagram . . . . .	<u>p. 58</u>
10.1.4	Connection diagram with seasonal switching . . . . .	<u>p. 59</u>
10.1.5	Generic thermostat connection diagram . . . . .	<u>p. 60</u>
<b>10.2</b>	<b>Connections . . . . .</b>	<b><u>p. 61</u></b>
10.2.1	Connection with 3 speed thermostats . . . . .	<u>p. 61</u>
10.2.2	Water probe management . . . . .	<u>p. 61</u>
<b>10.3</b>	<b>Error signals . . . . .</b>	<b><u>p. 61</u></b>
<b>11</b>	<b>0-10 V Connection Code B10042 . . . . .</b>	<b><u>p. 62</u></b>
	<b>Installation . . . . .</b>	<b><u>p. 62</u></b>
	Description . . . . .	<u>p. 62</u>
<b>11.1</b>	<b>Connection diagram . . . . .</b>	<b><u>p. 62</u></b>
<b>11.2</b>	<b>Connections with 0-10 V thermostats . . . . .</b>	<b><u>p. 63</u></b>
<b>11.3</b>	<b>LED signal . . . . .</b>	<b><u>p. 63</u></b>

# CODING

## 1.1 Coding accessories

This instruction manual refers to the following accessory codes.

Accessory description		Combinable products	Code
<b>Controls on the appliance</b>			
<b>M7 controls</b>			
	M7 on-board electronic control with continuously modulating thermostat, with remote control supplied as standard	All	ECA044II
	M7 on-board electronic control with built-in Wi-Fi module, with continuously modulating thermostat and remote control supplied as standard	All	EWA044II
<b>Wall-mounted control panels M7 series</b>			
<b>Printed circuit board M7</b>			
	Electronic board on board unit with continuous modulation. For connection to M7 wall control units	All	ESE045II
	Electronic board on board unit with continuous modulation. For connection to M7 wall control with Bluetooth	All	ESE046II
<b>Control panels</b>			
	LED electronic control panel with touch interface, wall-mounted complete with thermostat and room temperature and relative humidity probe. Cable connection. Colour white	All	EEB749II
	LED electronic control panel with touch interface, wall-mounted complete with thermostat and room temperature and relative humidity probe with integrated WiFi module, App Innova Butler. Cable connection. Colour white	All	EFB749II
	LED electronic control panel with touch interface, wall-mounted complete with thermostat and room temperature and relative humidity probe. Bluetooth connection. Colour white	All	EGB749II
<b>WALL MOUNTED STANDARD FANCOIL CONTROLS</b>			
<b>PCB</b>			
	On-board electronic printed circuit board for control from systems with 0-10 V analogue output.	All	B10042II
	On-board electronic printed circuit board for connection to 4-speed wall-mounted electromechanical thermostats.	All	B4V042II
<b>Control panels</b>			
	Wall mounted control with thermostat, summer/winter and speed selectors	All	B3V151II

## GENERAL INFORMATION

### 2.1 About the manual

This manual was written to provide all the explanations for the correct management of the appliance.

- ⚠ This instruction manual forms an integral part of the device and therefore must be carefully preserved and must ALWAYS travel with it, even if you transfer the device to another owner or relocate it to other premises. If the manual gets damaged or lost, download a copy from the website.
- ⚠ Read this manual carefully before proceeding with any operation and follow the instructions in the individual chapters.
- ⚠ The manufacturer is not responsible for damages to persons or property caused by failure to follow the instructions in this manual.
- ⚠ This document is restricted in use to the terms of the law and may not be copied or transferred to third parties without the express authorization of the manufacturer.

#### 2.1.1 Editorial pictograms

The pictograms in the next chapter provide the necessary information for correct, safe use of the machine in a rapid, unmistakable way.

#### Related to security

- ⚠ **High risk warning (bold text)**
  - The operation described above presents a risk of serious physical injury, fatality, major damage to the appliance and/or to the environment if not carried out in compliance with safety regulations.
- ⚠ Low risk warning (plain text)
  - The operation described above presents a risk of minor physical injury or minor damage to the appliance and/or to the environment if not carried out in compliance with safety regulations.
- ⊘ Prohibition (plain text)
  - Refers to prohibited actions.
- i **Important information (bold text)**
  - This indicates important information that must be taken into account during the operations.

#### In the texts

- ▶ procedures
- lists

#### In the control panels

- ▶ actions required  
*Expected responses following an action.*

#### In the figures

- 1 The numbers indicate the individual components.
- A The capital letters indicate component assemblies.
- ① The white numbers in black marks indicate a series of actions to be carried out in sequence.
- Ⓐ The black letter in white identifies an image when there are several images in the same figure.

#### 2.1.2 Pictograms on the product

Symbols are used in some parts of the appliance:

#### Related to security

- ⚠ **Caution: electrical danger**
  - The concerned personnel is informed to the presence of electricity and the risk of suffering an electric shock.

#### 2.1.3 Recipients

##### User

Non-expert person capable of operating the product in safe conditions for people, for the product itself and the environment, interpreting an elementary diagnostic of faults and abnormal operating conditions, carrying out simple adjustment, checking and maintenance operations.

##### Installer

Expert person qualified to position and connect (hydraulically, electrically, etc.) the unit to the plant; this person is responsible for handling and correct installation according to the instructions provided in this manual and the national standards currently in force.

##### Technical Service Centre

Expert and qualified person authorised directly by the manufacturer to carry out all routine and supplementary maintenance operations, as well as every adjustment, check, repair and replacement of parts necessary during the life of the unit itself.

#### 2.1.4 Manual organisation

The manual is divided into sections each dedicated to one or more target groups.

##### Coding

It addresses all recipients. It contains the list of products and/or accessories referred to in the manual.

##### General information

It addresses all recipients.

It contains general information and important warnings that should be known before installing and using the appliance.

### Installation

It is addressed exclusively to the installer.

It contains specific warnings and all the information necessary for positioning, mounting and connecting the appliance.

### Control panels

It is addressed only and exclusively to the Installer and the Technical Assistance Centre.

These are sections dedicated to the different types of controls and electronic boards combined with the range with specific information for that combination.

## 2.2 General warnings

- ⚠ Specific warnings are given in each chapter of the document and must be read before starting operations.
- ⚠ All personnel involved must be aware of the operations and dangers that may arise when beginning all unit installation operations.
- ⚠ Installation performed outside the warnings provided in this manual and use of the appliance outside the prescribed temperature limits will invalidate the warranty.
- ⚠ The installation and maintenance of climate control equipment could be dangerous because there is live electrical components inside the appliances. The installation, initial start-up and subsequent maintenance phases must be carried out exclusively by authorised and qualified personnel (see first start-up request form enclosed with the appliance).
- ⚠ Any contractual or extra-contractual liability for damage caused to persons, animals or property, due to installation, adjustment and maintenance errors or improper use is excluded. All uses not expressly indicated in this manual are not permitted.
- ⚠ Only qualified installer companies are authorised to install the device. After having completed installation, the installer will issue a declaration of conformity to the plant manager, as required by the applicable standards and the guidelines provided by contractor's instruction manual supplied with the device.
- ⚠ First start-up and repair or maintenance operations must be carried out by the Technical Assistance Centre or by qualified personnel following the provisions of this manual.
- ⚠ Do not modify or tamper with the appliance as this can lead to dangerous situations.
- ⚠ Use suitable accident-prevention clothing and equipment during installation and/or maintenance operations. The manufacturer is not liable for the non-observance of the current safety and accident prevention regulations.
- ⚠ In the event of liquid or oil leaks, set the master switch of the plant to "off" and close the water taps. Call the authorised Technical Assistance Centre or professionally qualified personnel as soon as possible and do not work on the appliance yourself.
- ⚠ In case of replacement of parts, use only original parts.
- ⚠ The manufacturer reserves the right to make changes to its models at any time to improve its product, without prejudice to the essential characteristics described in this manual. The manufacturer is not obliged to add such modifications to machines previously manufactured, already delivered or under construction.
- ⚠ The unit can be used by children over the age of 8, and by people with reduced physical, sensory or mental capabilities, or with no experience or necessary knowledge, as long as they are monitored or after they have received instructions on the safe use of the unit and have understood the dangers involved. Children must not play with the appliance. The cleaning and maintenance that must be performed by the user should not be carried out by children without supervision.

## 2.3 Basic rules of security

Please keep in mind that the use of products powered by electricity and water call for operators to comply with certain essential safety rules:

- ⊖ The use of the appliance to children and unassisted disabled persons is prohibited.
- ⊖ It is forbidden to touch the device with wet or damp body parts.
- ⊖ It is forbidden to carry out any operation before disconnecting the appliance from the power supply by setting the plant master switch to "off".
- ⊖ It is forbidden to modify the safety or adjustment devices or adjust without authorization and indications of the manufacturer.
- ⊖ It is forbidden to pull, unplug or twist the device's electric cables, even if it is disconnected from the mains.
- ⊖ It is forbidden to introduce objects and substances through the air inlet and outlet grilles.
- ⊖ It is forbidden to open the access doors of the device's internal parts without first having set main switch of the system to "off".
- ⊖ It is forbidden to dispose of, or leave in the reach of children, the packaging materials which could become a source of danger.

## 2.4 Disposal



The symbol on the product or packaging indicates that the product must not be treated as normal household waste, but must be taken to the appropriate collection point for recycling of used electrical and electronic equipment and batteries.

Proper disposal of this product avoids harm to humans and the environment and promotes the reuse of valuable raw materials.

For more detailed information about the recycling of this product, contact your local city office, your household waste disposal service or the shop where you purchased the product.

Illegal disposal of the product by the user involves the application of the administrative sanctions provided for by the regulations in force.

This provision is only valid in the EU Member States.

## PREPARATION FOR TOUCHPAD CONNECTION

### 3.1 Preliminary warnings

**⚠ The following procedure is required to connect the touchpad (ECA044 - EWA044).**

### 3.2 Preparation for command connection

#### Accompanying material

Accompanying the unit, contained in a bag placed on the cover of the electrical box, are:

- 1 terminal for power supply connection (L-N)
- cable gland
- 1 terminal for serial connection (-BA+)
- screws

#### 3.2.1 Preliminary warnings

- ⚠** Before doing any work, make sure that the supply power is disconnect.
- ⚠** All operations of an electrical nature must be carried out by qualified personnel having the necessary legal requirements, trained and informed about the risks related to such operations.
- ⚠** All connections must be made following the regulations in force in the country of installation.
- ⚠** The unit must only be powered after work has been completed.
- ⚠** Disconnect the main breaker before making any electrical connections and performing any type of operation.
- ⚠** Access to the electrical panel is only permitted to qualified personnel.
- ⚠** Refer to the respective section of the control used to make the electrical connections.

### 3.2.2 Device preparation

Before proceeding with the installation, it is necessary to remove some elements from the appliance.

1. Fixing screws
2. Upper grid

3. Cover cabinet

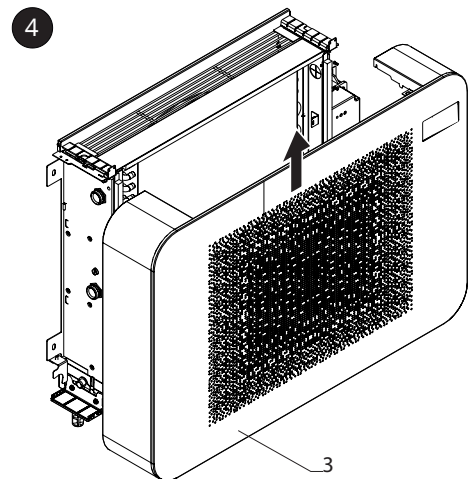
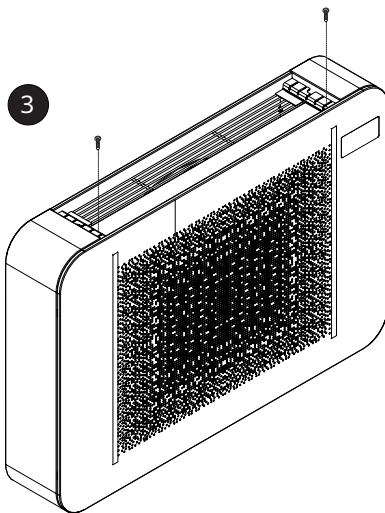
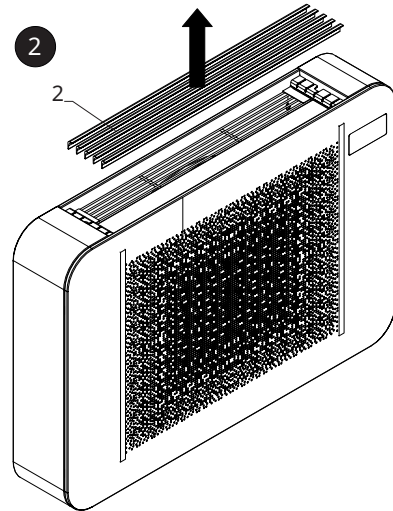
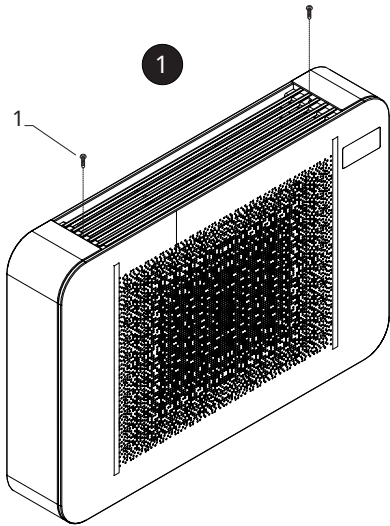

#### to remove the grid

- ▶ remove the fixing screws
- ▶ lift up and remove the upper grille

#### To remove the cover cabinet

- ▶ remove the fixing screws
- ▶ lift the cover cabinet
- ▶ remove the cover cabinet

### 3.2.3 Installation of electrical connection box

⚠ Normally the unit leaves the factory with the electrical box mounted.

⚠ In exceptional cases, the electrical box can be installed at a later stage.

- 1. Electrical box
- 2. Notches
- 3. Holes
- 4. Fixing screws

- 5. Cable strain relief clamp
- 6. Fixing of ground cable
- 7. Anchor plate for electrical box

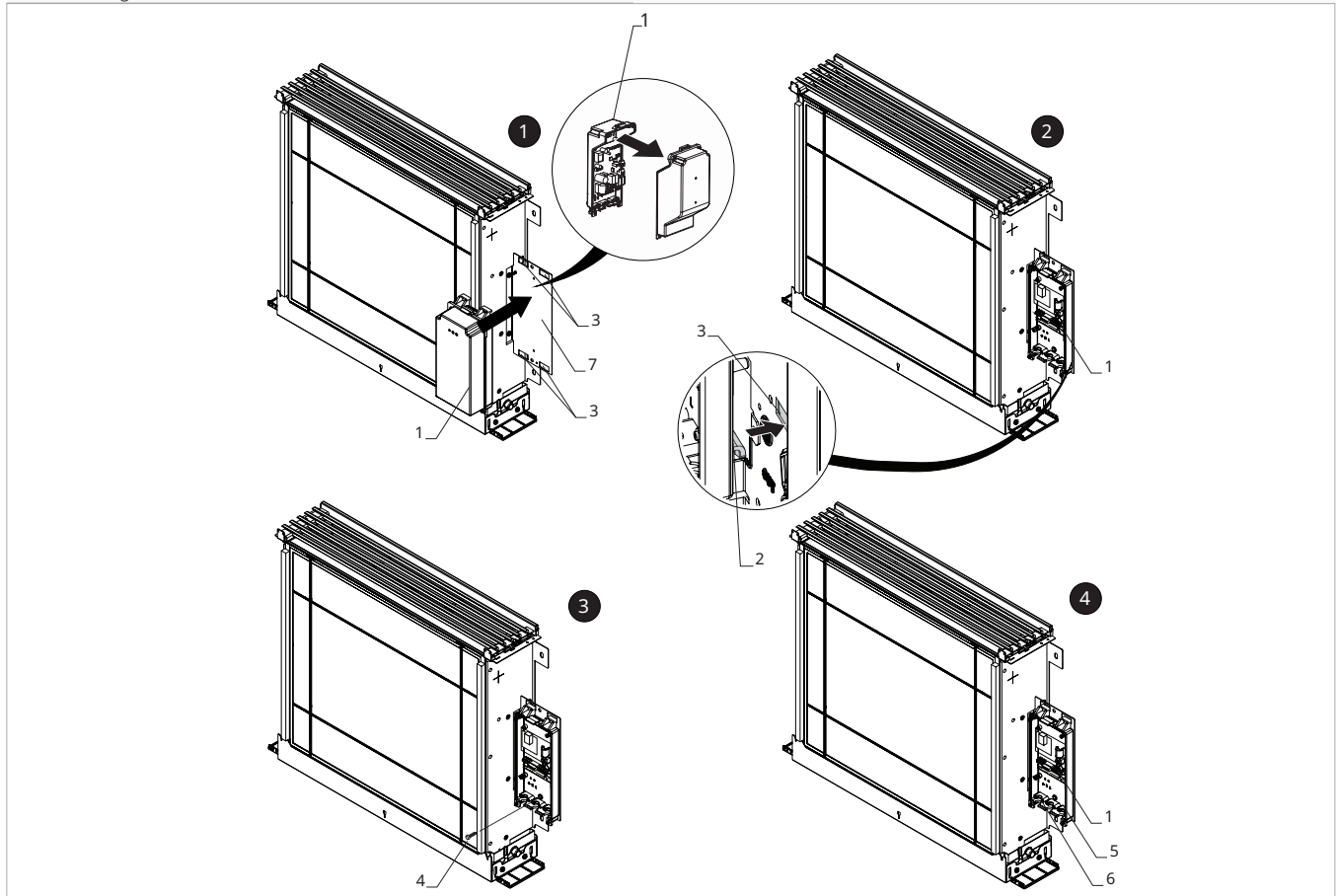

**In this case, to install the electrical box:**

- ▶ open the electrical box
- ▶ place the base of the electrical box in the appropriate holes on the plate prepared for anchoring the electrical box
- ▶ Wedge the notches of the electrical box into the appropriate holes
- ▶ fix the electrical box with the fixing screws provided
- ▶ secure the ground cable to the structure of the appliance with the screw provided

⚠ The minimum force that must be exerted for starting must be about 2 N.

- ▶ connect the connector to the MOTOR quick connector on the printed circuit board
- ▶ connect the water probe to the T2 connector on the device

⚠ The water temperature probe monitors the temperature inside the coils and determines fan start-up according to preset parameters. (winter minimum and summer maximum functions)

⚠ Check that the probe is correctly positioned in the compartment on the coil.

- ▶ connect the electrics

⚠ For models FÄRNA SMALL, it is mandatory to move Dip-switch A to ON

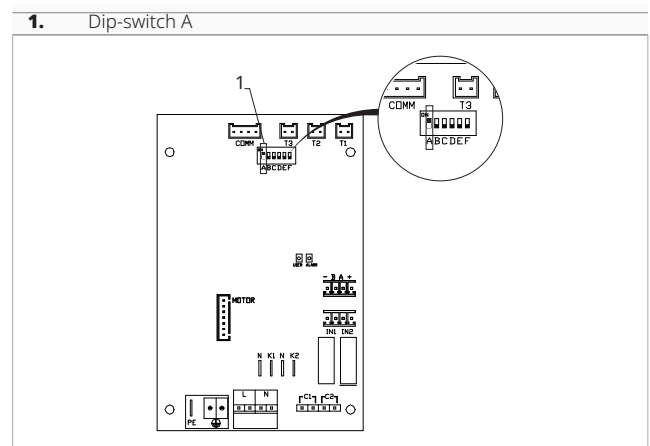

- ▶ tidy up the cables
- ▶ fix the cables using the grommets provided



### 3.2.4 Completed assembly

1. Electrical box
2. Fixing screws

3. Cover cabinet
4. Connectors

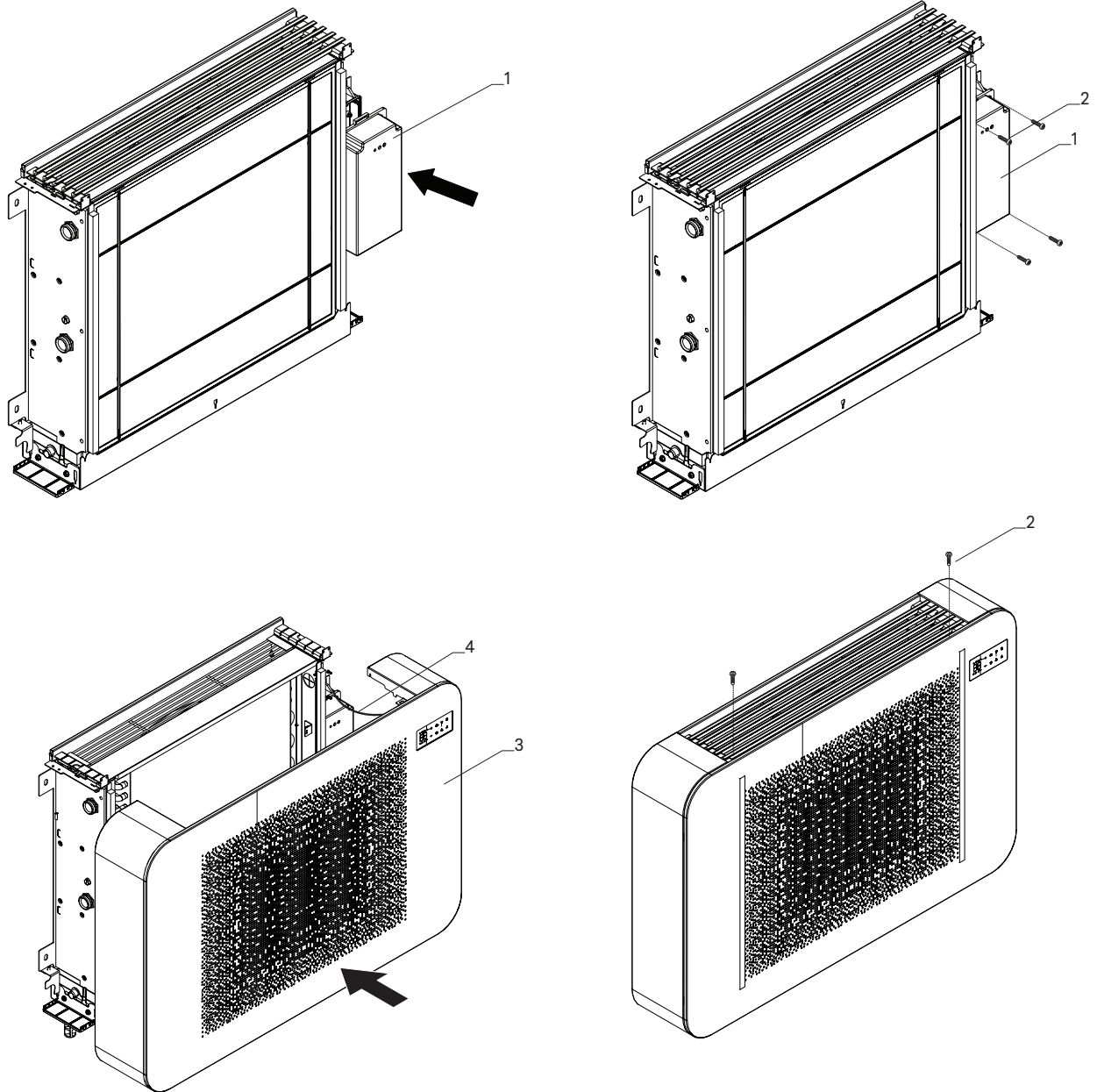

#### Completed assembly

- ▶ place the cover of the electrical box
- ▶ fix with screws
- ▶ connect the connector to the touchpad
- ▶ reassemble the unit

### 3.2.5 Access to the terminal block

1. Fixing screws

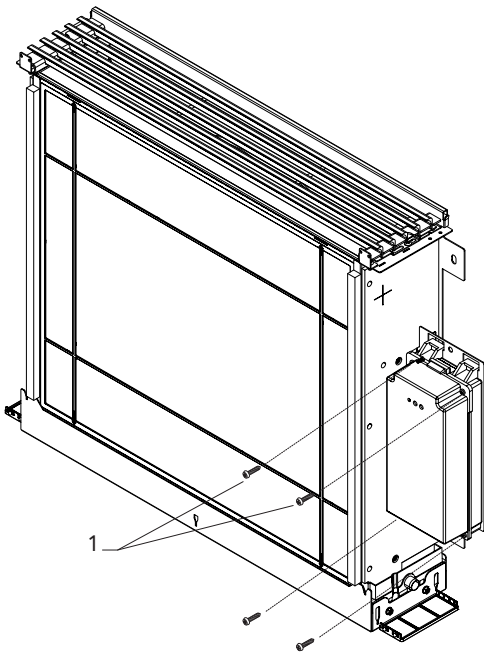

2. Cover of the electrical box

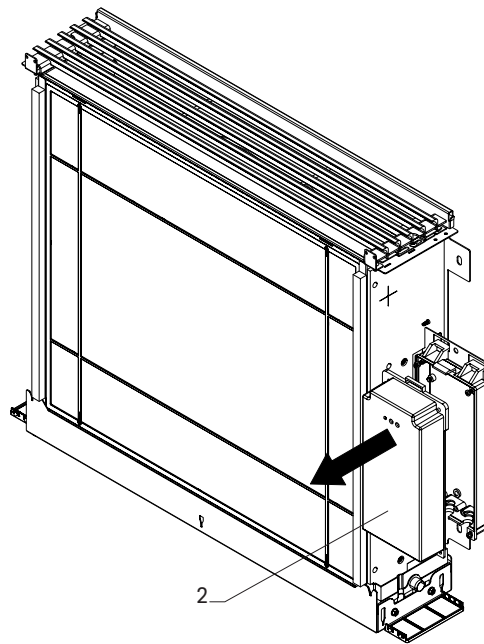

⚠ Before doing any work, make sure that the supply power is disconnect.

**To access:**

- ▶ if installed, remove the movable cover panel
- ▶ Disconnect the on-board display connector (if present)

**To access the connections:**

- ▶ unscrew the fixing screws of the electric box
- ▶ remove the lid from the junction box

**To make the connection:**

- ▶ bring the power cord to the terminal block
- ▶ making the connections
- ▶ reassemble the unit

⚠ Refer to the information in the wiring diagram of the unit you are installing.

⚠ Please refer to the sections of the respective controls for indications of electrical connections.

⚠ The electrical connection can be made by a cable recessed into the wall as indicated on the installation template ( connection recommended for installation of the device at the top of the wall).

⚠ It is necessary to check that the power supply is provided with appropriate protection against electric shorts and/or overloads

## TOUCHPAD AND REMOTE CONTROL CODE ECA044

### 4.1 Interface

1. Display area
2. Keys area

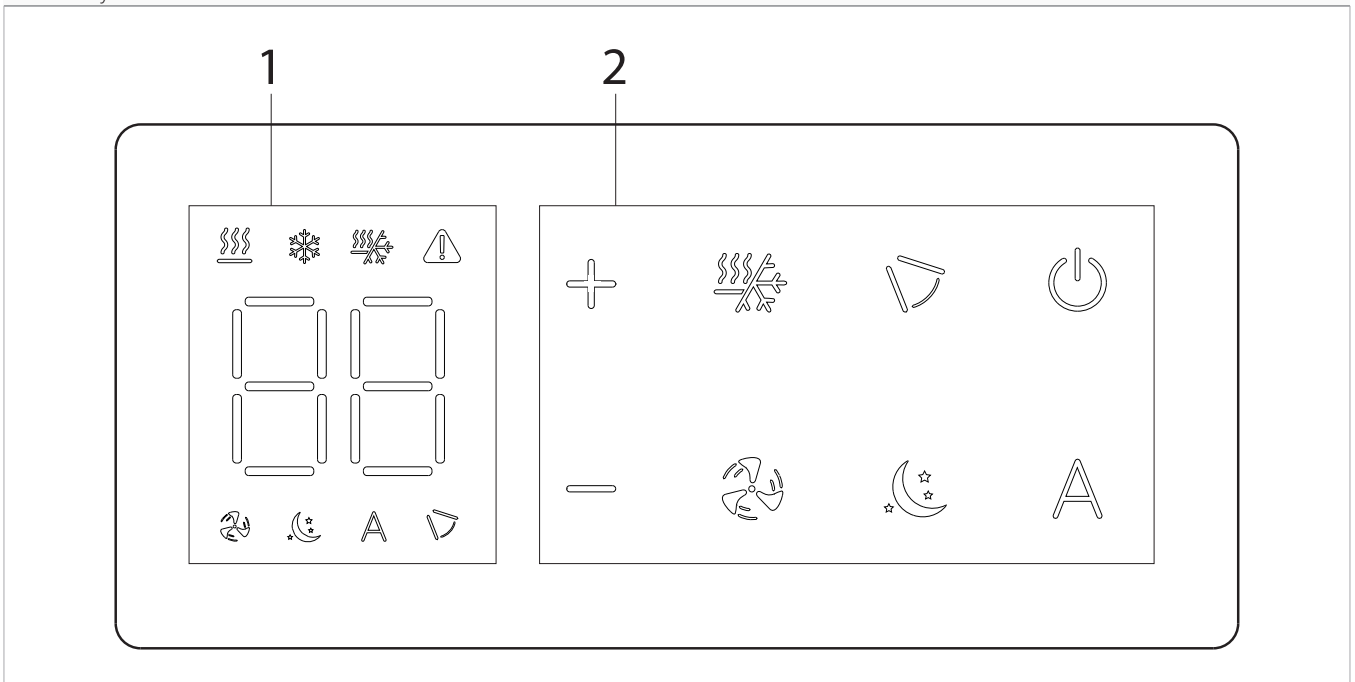

### 4.2 Description

The onboard control is available in two versions:

**ECA044**- Onboard control M7 with continuously modulating thermostat, with remote control supplied as standard.

### 4.3 Electronic board ECA044

The PCB is included in the supply.

<b>M1</b>	Fan motor DC Inverter
<b>PE</b>	Earth connection
<b>L-N</b>	Electrical power supply connection 230 V / 50 Hz
<b>Y1</b>	Water electrovalve (voltage output 230 V / 50 Hz / 1 A)
<b>CH/C1</b>	Cooling request contact (for example chiller or reversible heat pump). Activated in parallel with the solenoid valve output (Y1) with 1 minute delay when the fancoil is in cooling mode and is on call (potential-free contact max. 1 A).
<b>BO/C2</b>	Heating request contact (for example boiler or heat pump). Activated in parallel with the output of the solenoid valve (Y1)

<b>CP</b>	Presence contact (normally open)
<b>IN1</b>	Input for potential-free contact 1
<b>AIR/T1</b>	Air temperature probe
<b>H2/T2</b>	Water temperature probe
<b>DU</b>	Touchpad
<b>PU</b>	Electronic board on the unit

with 1 minute delay when the fancoil is in heating mode and is on call (potential-free contact max. 1 A).

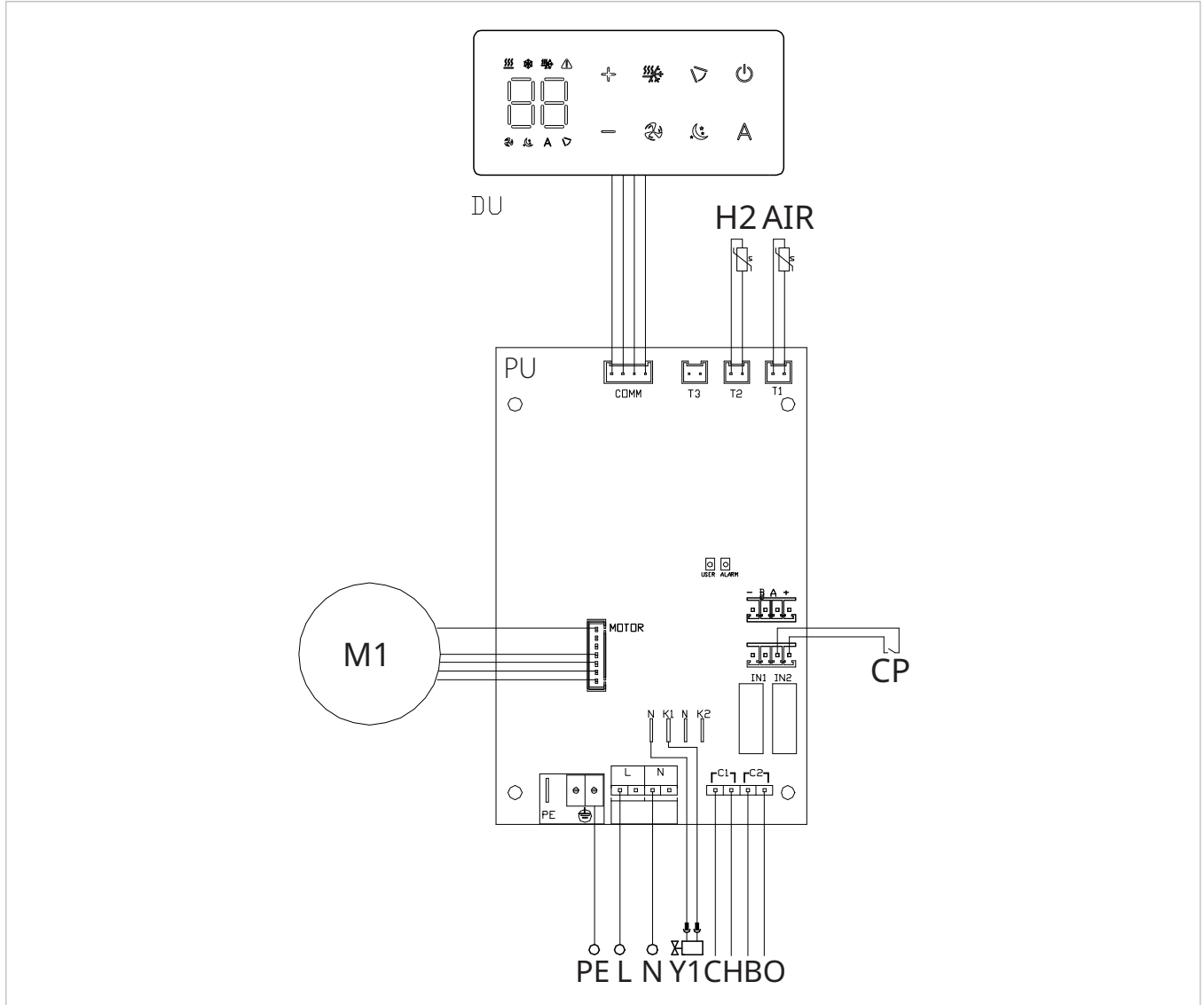

Through the water temperature probe H2/T2 (10 kΩ) located in the thermowell on the unit's coil, the temperature setpoints for fan stop are controlled:

- minimum temperature in heating mode (30 °C)

- maximum temperature in cooling mode (20 °C)

**⚠** The printed circuit board provides for operation without a water probe. In this case, the fan stop thresholds are ignored.

### 4.4 Connections

#### 4.4.1 Presence contact CP

Through this contact it is possible to connect an external device that inhibits the operation of the device, for example:

- opening window contact

- remote on/off
- infrared presence sensor
- enabling badge
- remote change of season

**Function**

*The contact is normally open.*

- ▶ when closing the CP contact, connected to a potential-free contact, the device switches to stand-by mode  
*CP appears on the display.*

- ▶ At the touch of a button on the display the symbol  flashes.

- ⊖ It is forbidden connect in parallel the CP input to one of another electronic board. Use separate contacts.





The CP presence contact can be configured for heating and cooling operation via the "To select digital input" [p. 18](#) settings menu item (digital input).

## 4.5 Functions



- ⚠ The keys of the remote control and touch-screen display perform the same function.

### 4.5.1 Basic menu

**To access the basic menu**

- ▶ with the display off, hold down  for 10 seconds  
*The device turns on and  appears*
- ▶ keep pressed until the indication  appears
- ▶ release the  key  
*The symbol  appears*

**To navigate in the menu**

- ▶ use the icons  



**To select a menu item and to confirm the changes made**

- ▶ press the icon   
*Confirming the change takes you to the next item.*





**To exit the menu**

- ▶ press the icon  for 10 seconds
- ▶ or wait 30 seconds the automatic shutdown

### Set AIR probe offset



- ⚠ The set value changes by 1 °C each press of the  and  buttons.

**To set the air probe regulation**

- ▶ select 
- ▶ press  to change settings
- ▶ increase or decrease the value with the icons  
- ▶ press  to confirm  
*By default it is set to 0.  
The setting range is from a minimum of -9 °C to a maximum of +9 °C.*





### Scale

**To change the temperature unit of measure**

- ▶ select 
- ▶ press  to change settings
- ▶ select °C o °F
- ▶ press  to confirm  
*By default the temperature unit of measure is °C.*

### Adjusting buzzer volume

**To change the volume**

- ▶ select 
- ▶ press  to change settings
- ▶ increase or decrease the value with the icons  
- ▶ press  to confirm  
*The volume setting range is from 00 (min) to 03 (max).*





- ⚠ The volume changes after confirm the modification.

### 4.5.2 Advanced Menu

- ⚠ **To access the Setup menu, it is necessary to access the Basic menu. See section "Basic menu" [p. 17](#).**



The special functions menu can be accessed via the control panel.

**To access the setup menu**

- ▶ from the basic menu press  Appears 
- ▶ press the  key once  
Appears 

- ▶ press  to confirm and log in  
*This takes you to the settings menu.*



#### To navigate in the menu

- ▶ use the icons  

#### To select a menu item and to confirm the changes made

- ▶ press  for 2 seconds  
*Confirming the change takes you to the next item.*

#### To exit the menu

- ▶ press  for about 10 seconds  
*Appears *
- ▶ press  for about 10 seconds  
*The display turns off.*
- ▶ or wait 30 seconds after the last action  
*The display is switched off automatically.*

- ⚠ After 30 seconds from the last action the control goes out and the settings is memorized.

## Menu items

**Ad:** Not used

**of:** Options for digital output

**UC:** Not used



**Ac:** Anti-stratification in cooling

**Ah:** Anti-stratification in heating

**Fr:** Not used

## To select digital input

#### To change the digital input







- ▶ select 
- ▶ press  to change settings
- ▶ select CP for contact presence (default)
- ▶ select CO to cooling open
- ▶ select CC to cooling close
- ▶ press  to confirm  
*By default digital input is set to CP.*

- ⚠ For return to the default settings, set the digital input to "CP".

- ⚠ By selecting one of the other inputs (CO,CC) the seasonality is locked. It is not possible to modify it through the key  of the control.

## Set the anti-stratification function to cooling







#### To set the anti-stratification function in cooling mode

- ▶ select 
- ▶ press  to change settings  
*Appears *
- ▶ press  to move within the menu
- ▶ select  to enable the function
- ▶ press  to confirm changes  
*By default, the anti-stratification function in cooling is set to *

- ⚠ The anti-stratification function in cooling is to be set for appliances installed at low floor level equipped with an active air probe.

## Set the anti-stratification function in heating mode

#### To set the anti-stratification function in heating mode

- ▶ select 
- ▶ press  to change settings  
*Appears *
- ▶ press  to move within the menu
- ▶ select  to enable the function
- ▶ press  to confirm changes  
*By default, the anti-stratification function in heating is set to *

- ⚠ The anti-stratification function in heating is to be set for appliances installed high up on the wall or ceiling equipped with an active air sensor.

## 4.5.3 Error signals

The PCB has a status LED.

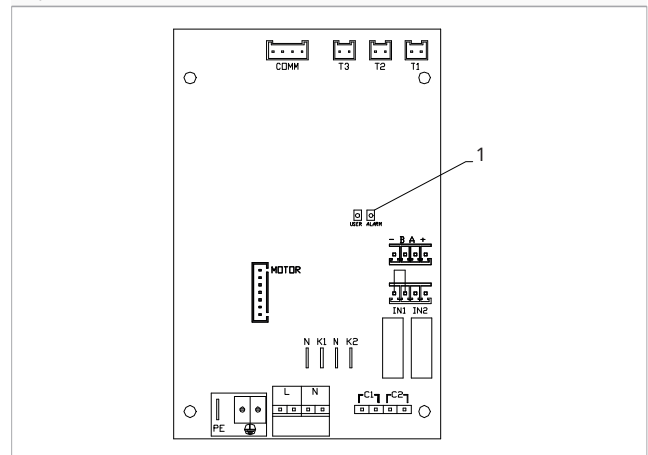

### 1. LED



- ⚠ The flashing LED indicates errors.
- ⚠ It is possible to verify the meaning of the LEDs by means of the error code displayed on the touchpad.
- ⚠ To identify the error, please refer to "Visualization of alarms on display" [p. 18](#).
- ⚠ With the LED on and no indication on the display, it is indicated that there are no errors.

## 4.5.4 Visualization of alarms on display

- ⚠ In the event of a malfunction, the display shows an alarm code.
- ⚠ In the event of an alarm, the device still maintains active functions.
  - ▶ E1 Room temperature probe AIR/T1 disconnected or faulty  
*None of the modes can be activated.*
  - ▶ E2 Faulty internal fan motor or disconnected  
*None of the modes can be activated.*

- ▶ E3 Water temperature probe H2/T2 disconnected or failure  
*None of the modes can be activated.*
- ▶ CE Communication error  
*Errors in the communication between the touchpad control and the board. None of the modes can be activated.*  
*The symbol  appears to indicate unsuitable radiant water.*
- ▶  lampeggiante Incorrect water temperature  
*In heating mode, the water temperature is below 30 °C.*
- ▶  lampeggiante Incorrect water temperature  
*In cooling mode, the water temperature is above 20 °C.*

## TOUCHPAD CODE EWA044

### 5.1 Interface

The touchpad control is supplied as standard on board the unit and does not require any connections.

1. Display area
2. Keys area

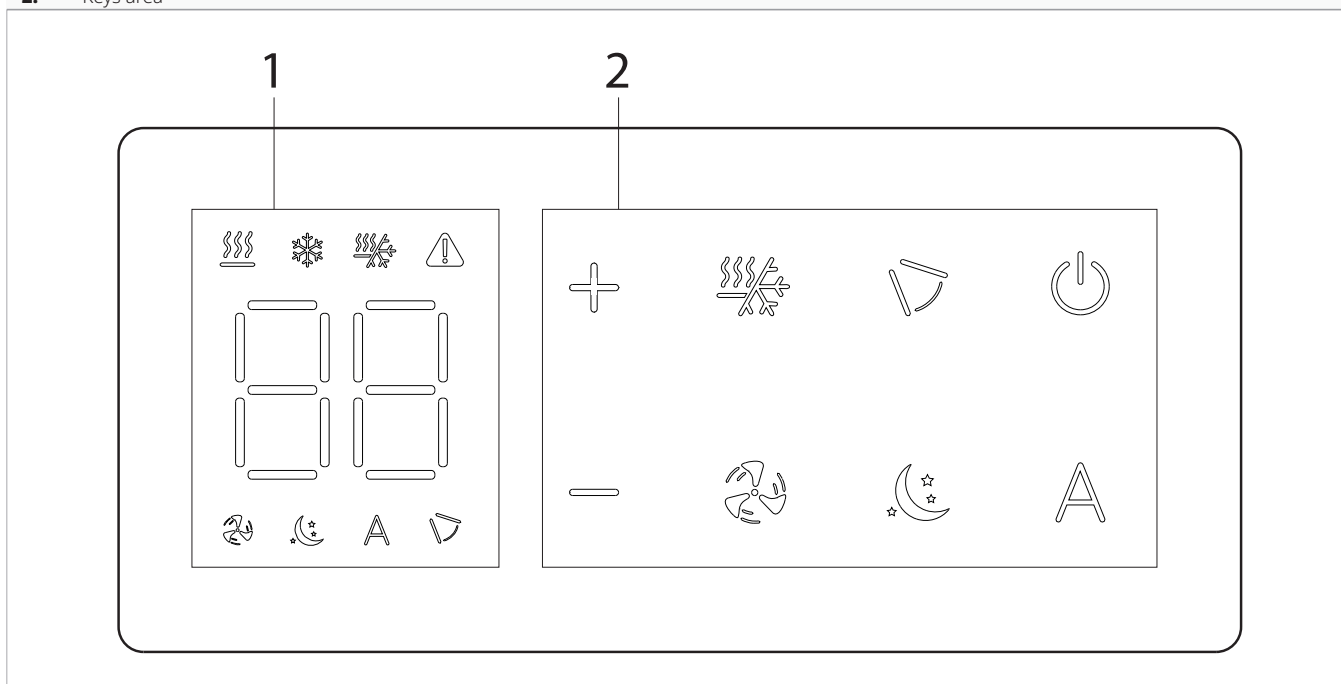

### 5.2 Description

**EWA044**- Onboard control M7 with integrated Wi-Fi module, with continuously modulating thermostat and remote control supplied as standard.

⚠ The app is available for onboard control M7 code EWA044.



### 5.3 Electronic board EWA044

The PCB is included in the supply.

<b>M1</b>	Fan motor DC Inverter
<b>PE</b>	Earth connection
<b>L-N</b>	Power supply connection 230 V / 50 Hz / 1 A
<b>Y1</b>	Water electrovalve
<b>CH/C1</b>	Cooling request contact (for example chiller or reversible heat pump). Activated in parallel with the solenoid valve output (Y1) with 1 minute delay when the fancoil is in cooling mode and is on call (potential-free contact max. 1 A).
<b>BO/C2</b>	Heating request contact (for example boiler or heat pump). Activated in parallel with the output of the solenoid valve (Y1)

<b>CP</b>	Presence contact (normally open)
<b>IN1</b>	Input for potential-free contact 1
<b>AIR/T1</b>	Air temperature probe
<b>H2/T2</b>	Water temperature probe
<b>DU</b>	Touchpad
<b>PU</b>	Electronic board on the unit
<b>WF</b>	Card for Wi-Fi connection

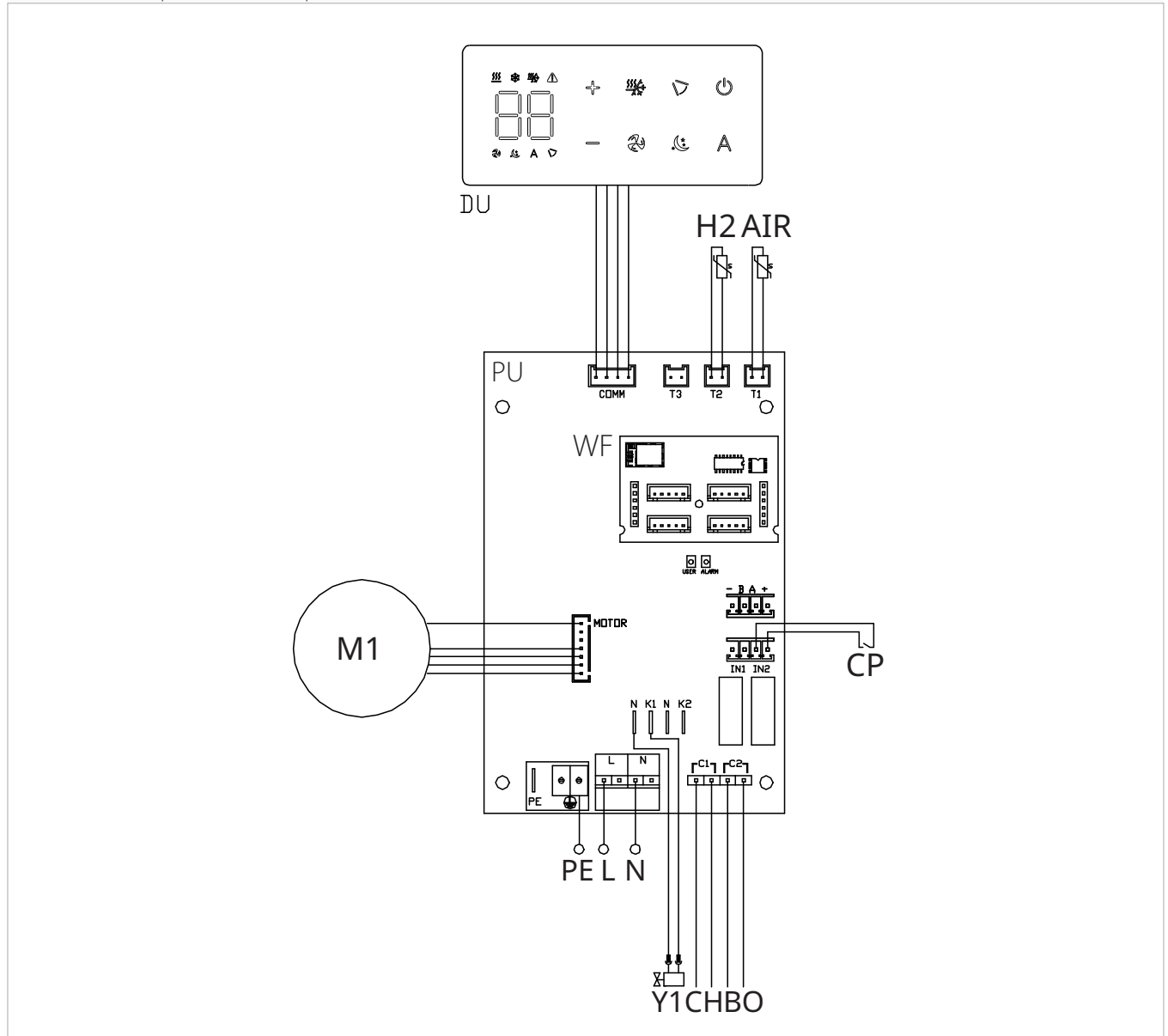

Through the water temperature probe H2/T2 (10 k $\Omega$ ) located in the thermowell on the unit's coil, the temperature setpoints for fan stop are controlled:

- minimum temperature in heating mode (30 °C)
- maximum temperature in cooling mode (20 °C)

**⚠** The printed circuit board provides for operation without a water probe. In this case, the fan stop thresholds are ignored.

## 5.4 Connections

### 5.4.1 Presence contact CP

Trough this contact it is possible connect an external device that inhibits the operation of the device, for example:

- opening window contact
- remote on/off
- infrared presence sensor
- enabling badge
- remote change of season

#### Function

*The contact is normally open.*





- ▶ when closing the CP contact, connected to a potential-free contact, the device switches to stand-by mode  
*CP appears on the display.*
- ▶ At the touch of a button on the display the symbol  flashes.

⊖ It is forbidden connect in parallel the CP input to one of another electronic board. Use separate contacts. The CP presence contact can be configured for heating and cooling operation via the "To select digital input" [p. 23](#) settings menu item (digital input).



## 5.5 Functions

### 5.5.1 Basic menu

#### To access the basic menu

- ▶ with the display off, hold down  for 10 seconds  
*The device turns on and  appears*
- ▶ keep pressed until the indication  appears
- ▶ release the  key  
*The symbol  appears*

#### To navigate in the menu

- ▶ use the icons  

#### To select a menu item and to confirm the changes made

- ▶ press the icon   
*Confirming the change takes you to the next item.*



#### To exit the menu

- ▶ press the icon  for 10 seconds
- ▶ or wait 30 seconds the automatic shutdown

*The range of settings is from a minimum of -9°C to a maximum of +9°C.*





### Scale

#### To change the temperature unit of measure

- ▶ select 
- ▶ press  to change settings
- ▶ select °C o °F
- ▶ press  to confirm  
*By default the temperature unit of measure is ° C.*

### Adjusting buzzer volume









#### To change the volume

- ▶ select 
- ▶ press  to change settings
- ▶ increase or decrease the value with the icons  
- ▶ press  to confirm  
*The volume setting range is from 00 (min) to 03 (max).*

 The volume changes after confirm the modification.

### Wi-Fi reset

#### To reset the Wi-Fi credentials and return the device to its original configuration

- ▶ select 
- ▶ press  to change settings
- ▶ use the   icons in sequence  
*Appears *
- ▶ press 
- ▶  *appears to reset Wi-Fi credentials.*
- ▶ press  to confirm  
*Credentials have been reset.*

### Menu items

**ot:** AIR probe offset (air probe setting)

**CF:** Scale

**ub:** Buzzer volume





**uu:** Wi-Fi reset

**uP:** Wi-Fi pairing

### Set AIR probe offset





 The set value changes by 1 °C each press of the  and  buttons.



#### To set the air probe regulation

- ▶ select 
- ▶ press  to change settings
- ▶ increase or decrease the value with the icons  
- ▶ press  to confirm  
*By default it is set to 0.*

## Activate Wi-Fi

### To activate Wi-Fi

- ▶ select 
- ▶ press  to change settings
- ▶ use the   icons in sequence  
*Appears *

- ▶ press 
- ▶  appears to enable Wi-Fi pairing.
- ▶ press  to confirm





 The device remains visible on the App for the first 15 minutes after the device is switched on.

## 5.5.2 Advanced Menu



 **To access the Setup menu, it is necessary to access the Basic menu. See section "Basic menu" p. 22.**

The special functions menu can be accessed via the control panel.

### To access the setup menu

- ▶ from the basic menu press 
- Appears *
- ▶ press the  key once  
*Appears *
- ▶ press  to confirm and log in  
*This takes you to the settings menu.*



### To navigate in the menu

- ▶ use the icons  

### To select a menu item and to confirm the changes made

- ▶ press  for 2 seconds  
*Confirming the change takes you to the next item.*

### To exit the menu

- ▶ press  for about 10 seconds  
*Appears *
- ▶ press  for about 10 seconds  
*The display turns off.*
- ▶ or wait 30 seconds after the last action  
*The display is switched off automatically.*

 After 30 seconds from the last action the control goes out and the settings is memorized.

## Menu items

**Ad:** Not used

**of:** Options for digital output

**UC:** Not used



**Ac:** Anti-stratification in cooling

**Ah:** Anti-stratification in heating



**Fr:** Not used

## To select digital input

### To change the digital input







- ▶ select 
- ▶ press  to change settings
- ▶ select CP for contact presence (default)
- ▶ select CO to cooling open
- ▶ select CC to cooling close
- ▶ press  to confirm  
*By default digital input is set to CP.*

 For return to the default settings, set the digital input to "CP".

 By selecting one of the other inputs (CO,CC) the seasonality is locked. It is not possible to modify it through the key  of the control.

## Set the anti-stratification function to cooling







### To set the anti-stratification function in cooling mode

- ▶ select 
- ▶ press  to change settings  
*Appears *
- ▶ press  to move within the menu
- ▶ select  to enable the function
- ▶ press  to confirm changes  
*By default, the anti-stratification function in cooling is set to *

 The anti-stratification function in cooling is to be set for appliances installed at low floor level equipped with an active air probe.

## Set the anti-stratification function in heating mode

### To set the anti-stratification function in heating mode

- ▶ select 
- ▶ press  to change settings  
*Appears *
- ▶ press  to move within the menu
- ▶ select  to enable the function
- ▶ press  to confirm changes  
*By default, the anti-stratification function in heating is set to *

 The anti-stratification function in heating is to be set for appliances installed high up on the wall or ceiling equipped with an active air sensor.

## 5.5.3 Error signals

The PCB has a status LED.

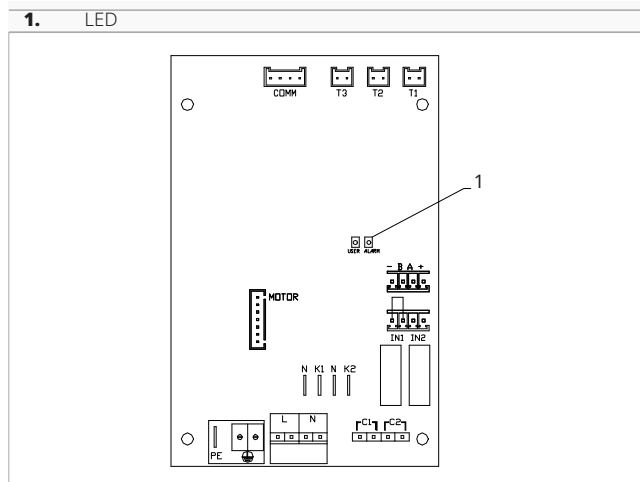

- ⚠ The flashing LED indicates errors.
- ⚠ It is possible to verify the meaning of the LEDs by means of the error code displayed on the touchpad.
- ⚠ To identify the error, please refer to "Visualization of alarms on display" [p. 24](#).
- ⚠ With the LED on and no indication on the display, it is indicated that there are no errors.

#### 5.5.4 Visualization of alarms on display

- ⚠ In the event of a malfunction, the display shows an alarm code.
- ⚠ In the event of an alarm, the device still maintains active functions.

- ▶ E1 Room temperature probe AIR/T1 disconnected or faulty  
*None of the modes can be activated.*
- ▶ E2 Faulty internal fan motor or disconnected  
*None of the modes can be activated.*
- ▶ E3 Water temperature probe H2/T2 disconnected or failure  
*None of the modes can be activated.*
- ▶ CE Communication error  
*Errors in the communication between the touchpad control and the board. None of the modes can be activated.*  
*The symbol ⚠ appears to indicate unsuitable radiant water.*
- ▶ 🌊 lampeggiante Incorrect water temperature  
*In heating mode, the water temperature is below 30 °C.*
- ▶ ❄ lampeggiante Incorrect water temperature  
*In cooling mode, the water temperature is above 20 °C.*

## PREPARATION FOR CONNECTING M7 SERIES WALL CONTROLS

### 6.1 Preliminary warnings

- ⚠ The following procedure is required to connect the wall controls (EEB749II - EFB749II - EGB749II - B3V151II).**

### 6.2 Preparation for command connection

#### Accompanying material

Accompanying the unit, contained in a bag placed on the cover of the electrical box, are:

- 1 terminal for power supply connection (L-N)
- cable gland
- 1 terminal for serial connection (-BA+)
- screws

#### 6.2.1 Preliminary warnings

- ⚠** Before doing any work, make sure that the supply power is disconnect.
- ⚠** All operations of an electrical nature must be carried out by qualified personnel having the necessary legal requirements, trained and informed about the risks related to such operations.
- ⚠** All connections must be made following the regulations in force in the country of installation.
- ⚠** The unit must only be powered after work has been completed.
- ⚠** Disconnect the main breaker before making any electrical connections and performing any type of operation.
- ⚠** Access to the electrical panel is only permitted to qualified personnel.
- ⚠** Refer to the respective section of the control used to make the electrical connections.

## 6.2.2 Device preparation

Before proceeding with the installation, it is necessary to remove some elements from the appliance.

- |   |  |
|---|--|
| <ol style="list-style-type: none"> <li>1. Fixing screws</li> <li>2. Upper grid</li> </ol> | <ol style="list-style-type: none"> <li>3. Cover cabinet</li> </ol> |
|---|--|

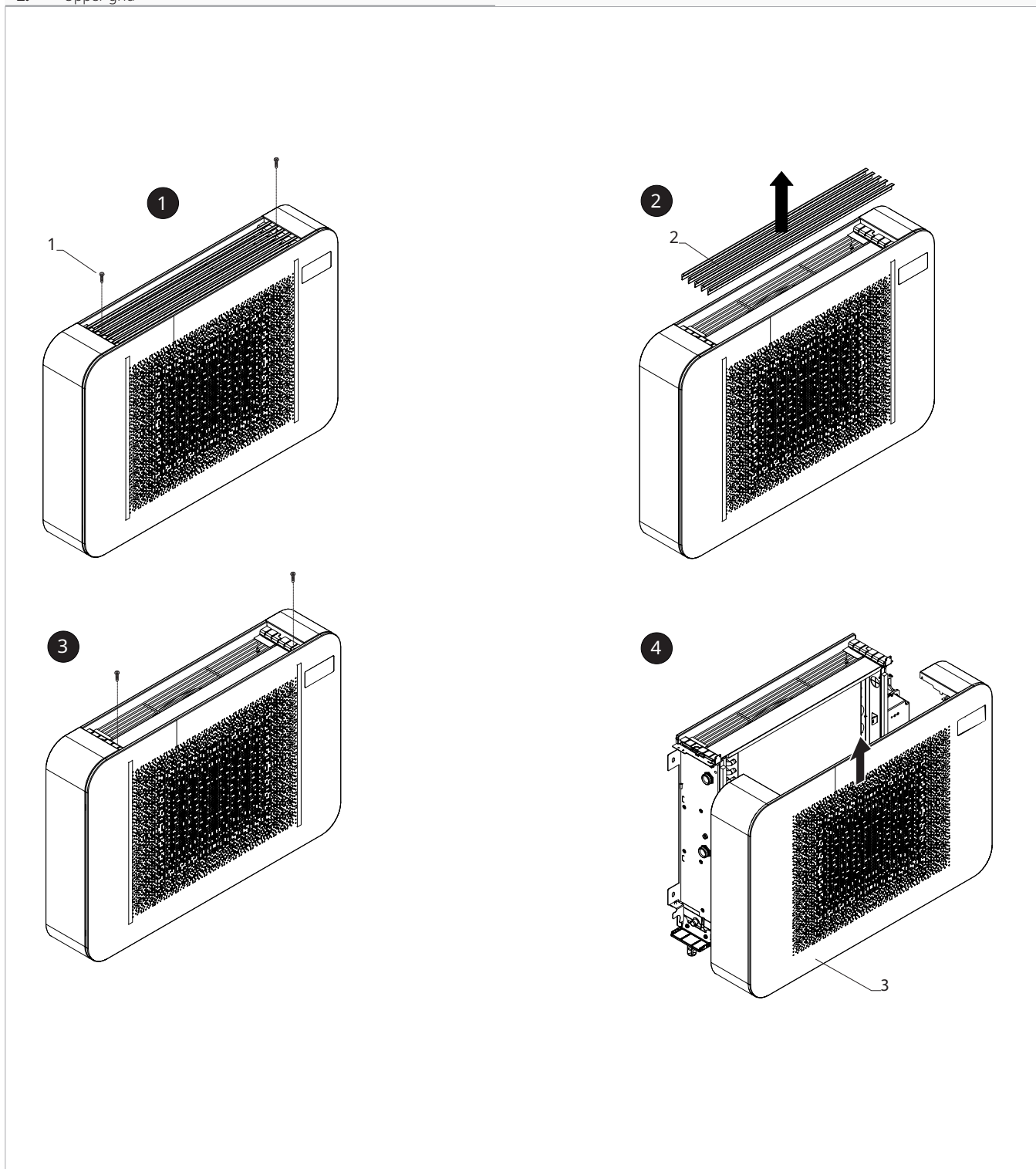

### to remove the grid

- ▶ remove the fixing screws
- ▶ lift up and remove the upper grille

### To remove the cover cabinet

- ▶ remove the fixing screws
- ▶ lift the cover cabinet

- ▶ Disconnect the on-board display connector (if present)
- ▶ remove the cover cabinet

### 6.2.3 Installation of electrical connection box

⚠ Normally the unit leaves the factory with the electrical box mounted.

⚠ In exceptional cases, the electrical box can be installed at a later stage.

1. Electrical box
2. Notches
3. Holes
4. Fixing screws

5. Cable strain relief clamp
6. Fixing of ground cable
7. Anchor plate for electrical box

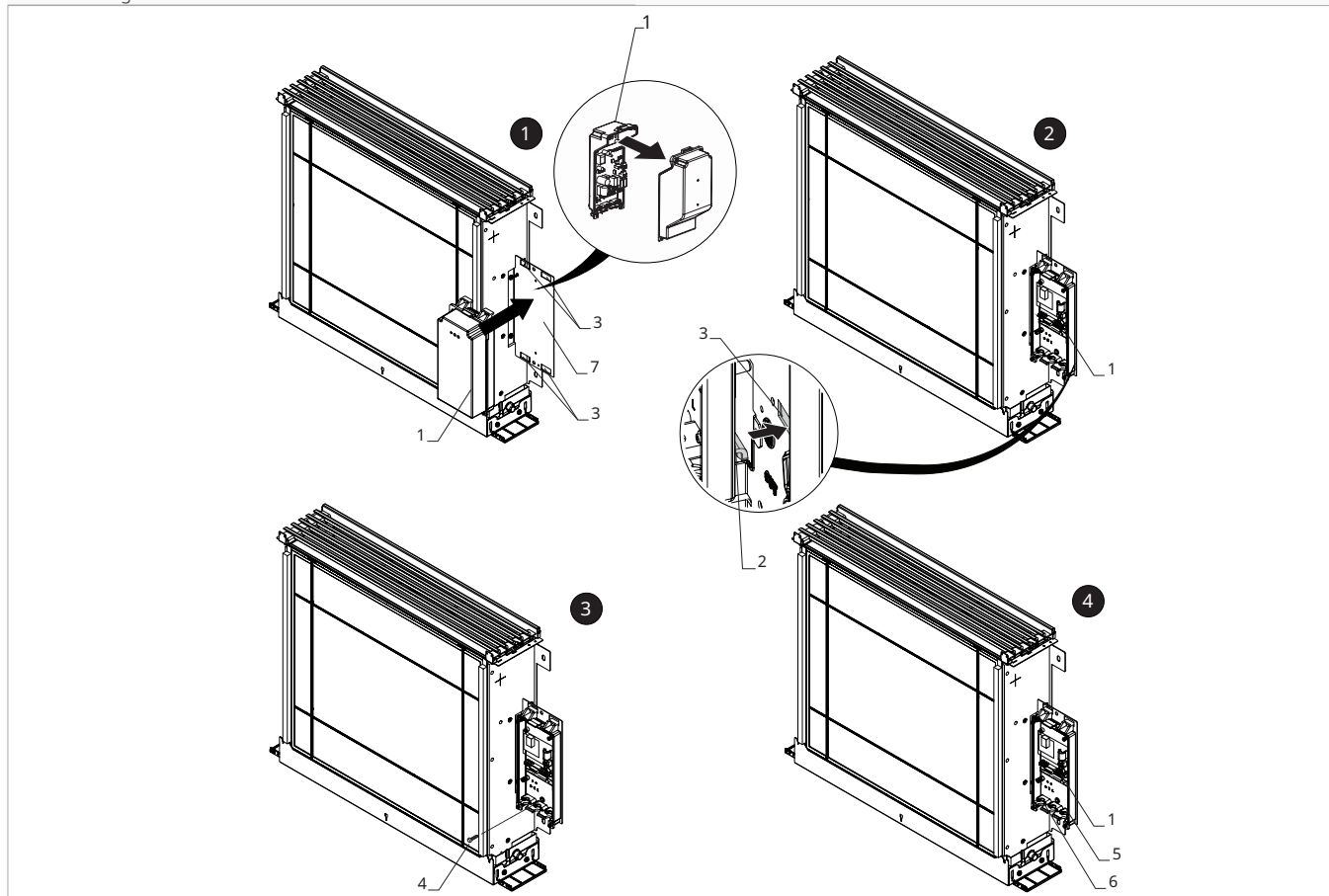

**In this case, to install the electrical box:**

- ▶ open the electrical box
- ▶ place the base of the electrical box in the appropriate holes on the plate prepared for anchoring the electrical box
- ▶ Wedge the notches of the electrical box into the appropriate holes
- ▶ fix the electrical box with the fixing screws provided
- ▶ secure the ground cable to the structure of the appliance with the screw provided

⚠ The minimum force that must be exerted for starting must be about 2 N.

- ▶ connect the connector to the MOTOR quick connector on the printed circuit board
- ▶ connect the water probe to the T2 connector on the device

⚠ The water temperature probe monitors the temperature inside the coils and determines fan start-up according to preset parameters. (winter minimum and summer maximum functions)

⚠ Check that the probe is correctly positioned in the compartment on the coil.

- ▶ connect the electrics

⚠ For models FÄRNA SMALL, it is mandatory to move Dip-switch A to ON

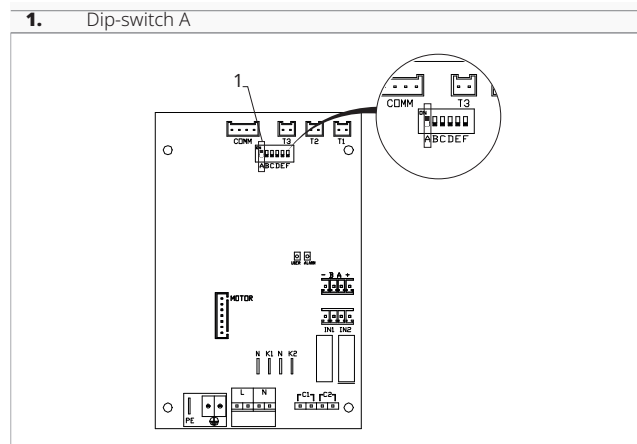

- ▶ tidy up the cables
- ▶ fix the cables using the grommets provided

### 6.2.4 Completed assembly

#### Completed assembly

- ▶ place the cover of the electrical box

- ▶ fix with screws
- ▶ reassemble the unit

### 6.2.5 Access to the terminal block

1. Fixing screws

2. Cover of the electrical box

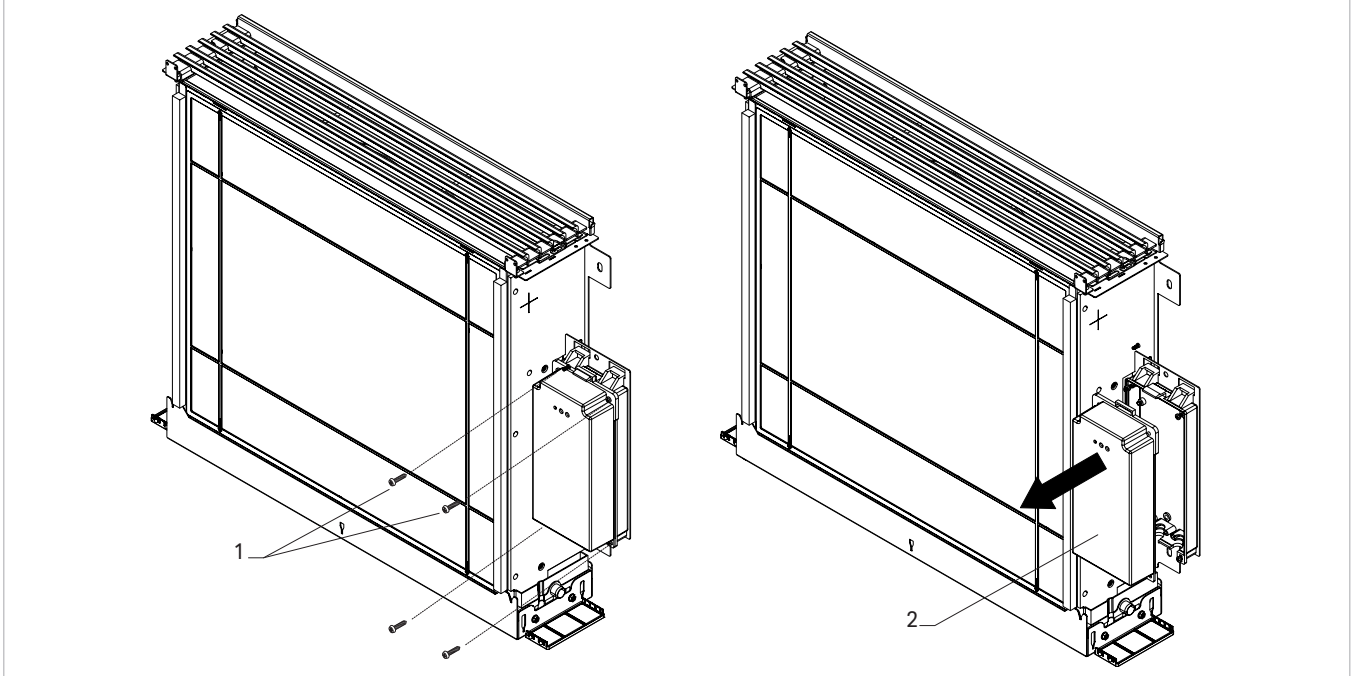

⚠ Before doing any work, make sure that the supply power is disconnect.

**To access:**

- ▶ if installed, remove the movable cover panel

**To access the connections:**

- ▶ unscrew the fixing screws of the electric box
- ▶ remove the lid from the junction box

**To make the connection:**

- ▶ bring the power cord to the terminal block
- ▶ making the connections
- ▶ reassemble the unit

⚠ Refer to the information in the wiring diagram of the unit you are installing.

⚠ Please refer to the sections of the respective controls for indications of electrical connections.

⚠ The electrical connection can be made by a cable recessed into the wall as indicated on the installation template ( connection recommended for installation of the device at the top of the wall).

⚠ It is necessary to check that the power supply is provided with appropriate protection against electric shorts and/or overloads



## M7 SERIES CONTROL CODE EEB749

### 7.1 Interface

1. Display area
2. Keys area

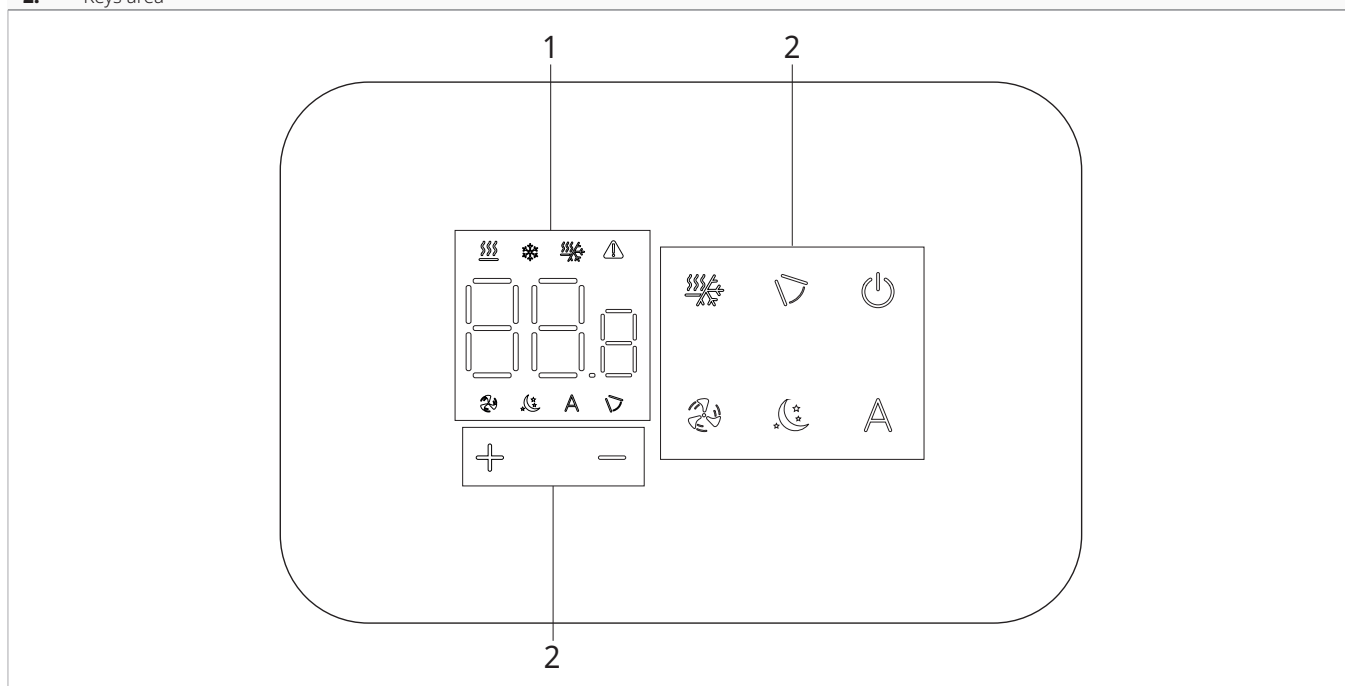

### 7.2 Installation

#### 7.2.1 Description

the wall-mounted remote control is an electronic LED thermostat with a touch interface, with the possibility of control over multiple appliances equipped with the same electronic board. It is equipped with a temperature and humidity probe.

⚠ The control can control up to a maximum of 16 units.

#### 7.2.2 Mounting

⚠ The control panel for wall control is to be installed inside a 503 electrical box.

⚠ A wall must be prepared to accommodate the 503 electrical box before installing the wall control.

⚠ Ensure that:

- the wall supports the weight of the appliance
- the section of floor or wall does not concern piping or electrical lines
- the functionality of load-bearing elements is not compromised

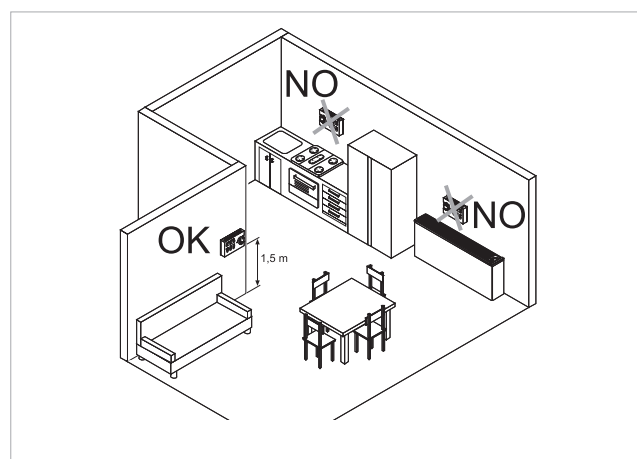

The wall-mounted remote control must be installed:

- on internal walls
- at a height of about 1,5 m from the floor
- away from doors or windows
- away from heat sources (heaters, convectors, stoves, direct sunlight)

⚠ The wall control is provided inside the package already assembled.

- 1. Base of control
- 2. Wall-mounted control panel

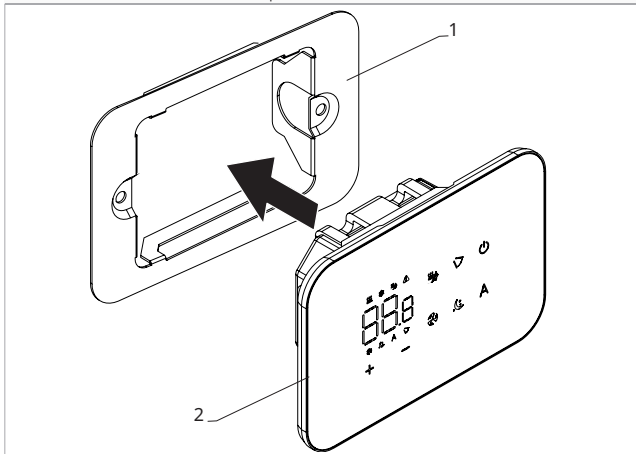

**Before wall installation:**

- ▶ separate the control base from the control panel

- 1. Fixing screws
- 2. Base of control
- 3. Holes for fixing to electrical box
- 4. Electric box 503

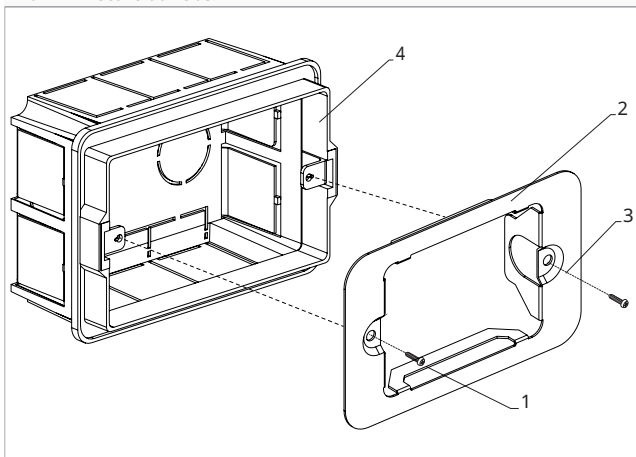

**For wall mounting of the control panel:**

- ▶ fix the control base to the electrical box 503 with screws
- ▶ connect the electrics

⚠ Before making the connections, please verify that the control terminal block is on the right-hand side.

- 1. Electric box 503
- 2. Base of control
- 3. Wall-mounted control panel

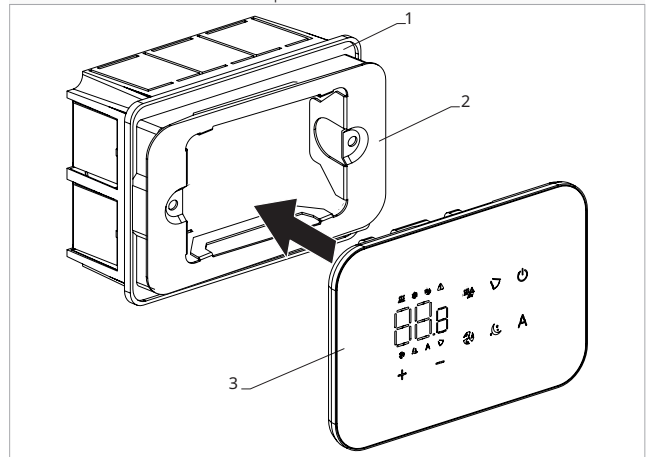

- ▶ Close the control panel

⚠ Pay attention not to crush the conductors when you close the control.

### 7.3 Single connection diagram

<b>M1</b>	Fan motor DC Inverter
<b>PE</b>	Earth connection
<b>L-N</b>	Power supply connection 230 V / 50 Hz / 1 A
<b>Y1</b>	Water electrovalve (voltage output 230 V / 50 Hz / 1 A)
<b>CH/C1</b>	Cooling request contact (for exemple chiller or reversible heat pump). Activated in parallel with the solenoid valve output (Y1) with 1 minute delay when the fancoil is in cooling mode and is on call (potential-free contact max. 1 A).
<b>BO/C2</b>	Heating request contact (for example boiler or heat pump). Activated in parallel with the output of the solenoid valve (Y1)

<b>+BA-</b>	Serial connection for wall-mounted remote control (respect AB polarization)
<b>IN1</b>	Potential-free input 1(not active)
<b>H2/T2</b>	Water temperature probe
<b>CP</b>	Presence contact (normally open)
<b>LU</b>	Electronic board for pairing control and device
<b>PU</b>	Electronic board on the unit
<b>M7</b>	M7 series wall control command

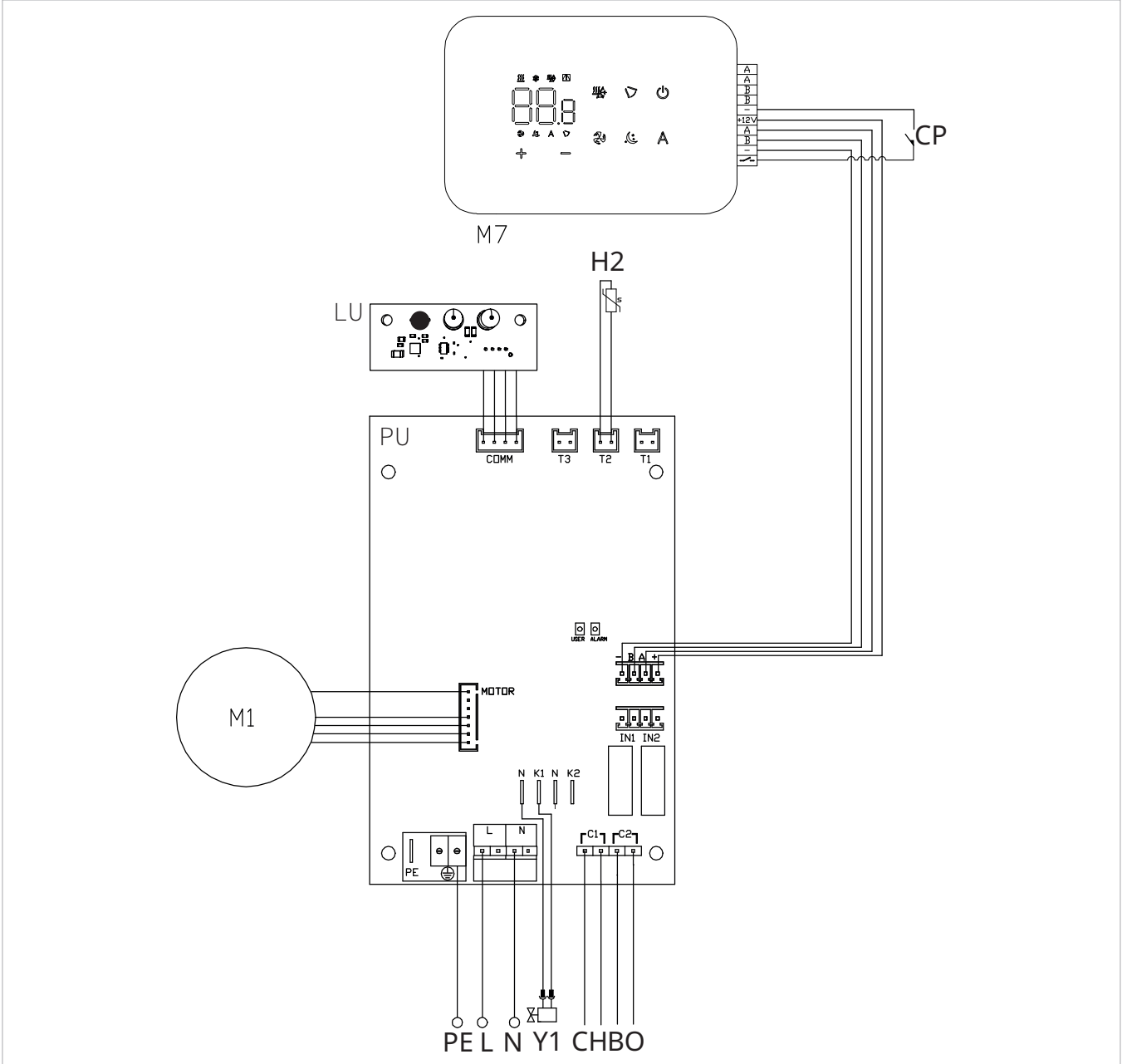

## 7.4 Multiple connection diagram

- |    |                                      |    |                                      |
|----|--------------------------------------|----|--------------------------------------|
| 1. | M7 series wall control panel         | 3. | PCB                                  |
| 2. | Terminal block for device connection | 4. | Board for pairing control and device |

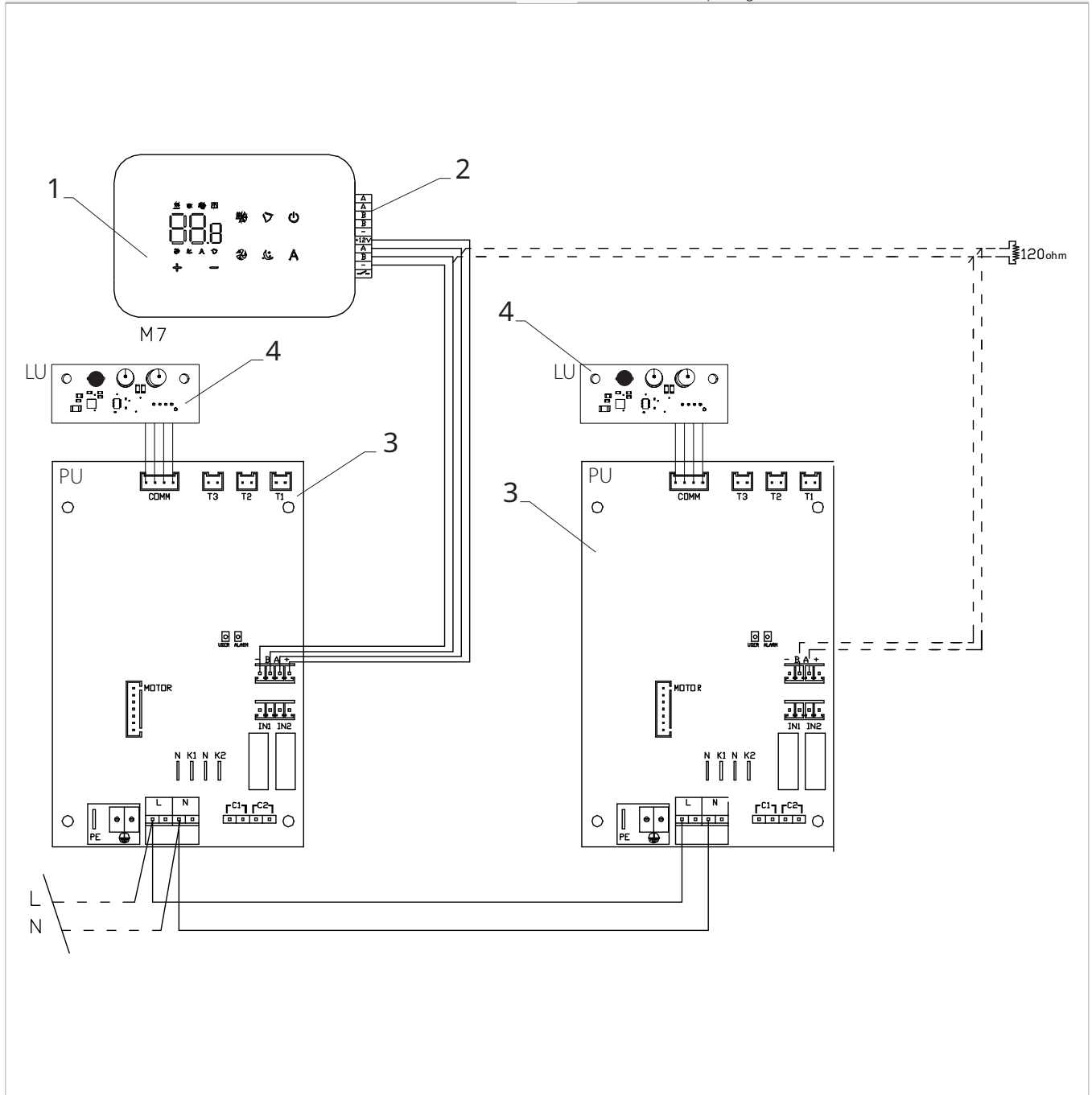

⚠ With multiple command linkage, it is mandatory to perform command-to-device matching. See section "Pairing of control and unit" [p. 36](#)

## 7.5 Connections

### 7.5.1 Preliminary warnings

⚠ The terminals for connecting the control panel and the presence contact CP are placed in a plastic bag and positioned inside the cover of the electrical box.

1. Terminal blocks

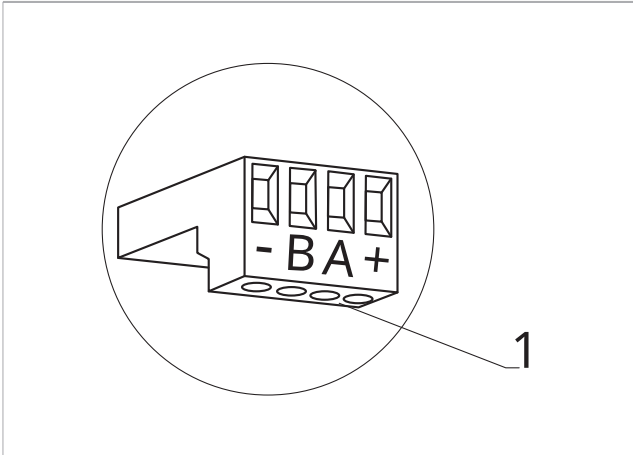

#### The terminals accept:

- rigid or flexible wires with a 0.2 to 1 mm<sup>2</sup> cross-section
- rigid or flexible wires with 0,5 mm<sup>2</sup> cross-section if two wires are connected to the same terminal block
- rigid or flexible wires with 0,75 mm<sup>2</sup> cross-section if the wires have wire end ferrules with a plastic collar

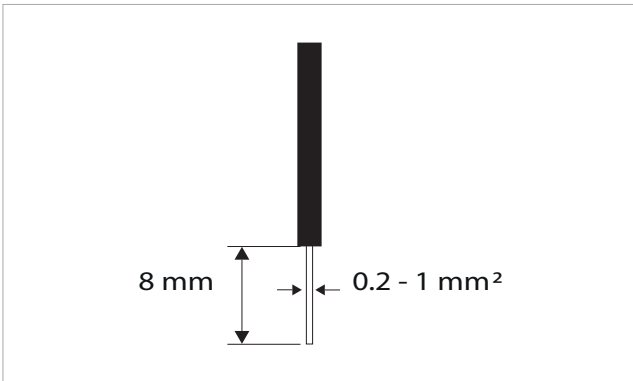

#### To connect the cables:

- ▶ strip 8 mm of the wire
- ▶ if the wire is rigid, you can insert it easily whereas
- ▶ if it is flexible, use appropriate crimp terminals
- ▶ push the wire completely in
- ▶ check the right fixing by pulling it gently

### 7.5.2 Control Panel

⚠ The control panel for wall control must be ordered separately.

#### Terminal block position:

1. Terminal block ( Back view panel)

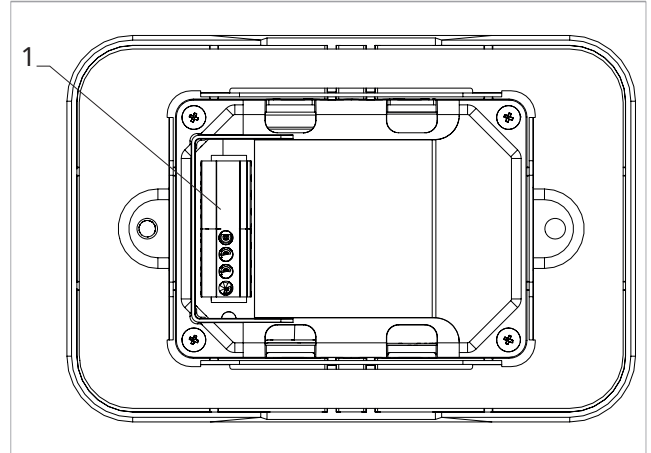

1. Terminal blocks

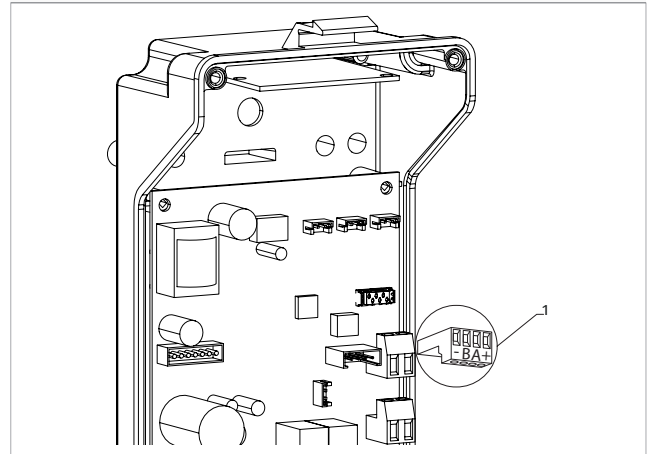

#### To connect the wall control panel to the board:

- ▶ connect the power supply cables to the + - terminals
- ▶ connect the ModBus serial connection cables to terminals A and B

### 7.5.3 Presence contact CP

Trough this contact it is possible connect an external device that inhibits the operation of the device, for example:

- opening window contact
- remote on/off
- infrared presence sensor
- enabling badge
- remote change of season

#### Function

*The contact is normally open.*

- ▶ when closing the CP contact, connected to a potential-free contact, the device switches to stand-by mode  
*CP appears on the display.*
- ▶ At the touch of a button on the display the symbol ⚠ flashes.

⊖ It is forbidden connect in parallel the CP input to one of another electronic board. Use separate contacts.

The CP presence contact can be configured for heating and cooling operation via the "To select digital input" [p. 35](#) settings menu item (digital input).

### 7.5.4 RS485 Serial Connection

The wall-mounted remote control can be connected through a RS485 serial line to one or more device, for a maximum of 16.

The devices must be equipped with an electronic board suitable for remote control.

For the connection:

- ▶ follow the indication on the connection diagram
- ▶ connect respecting the indication A and B

- ⚠ Use a bipolar shielded cable suitable for the RS485 serial connection with a minimum section of 0,35 mm<sup>2</sup>.
- ⚠ Keeping the bipolar cable separate from power supply cables.
- ⚠ Chase out the wall in order to minimize the length of the leads.
- ⚠ Complete the line with the 120 Ω resistance.
- ⊖ It is forbidden make star connections.
- ⚠ In the case of a connection between several devices, it is mandatory to carry out the matching between control and device. See section "Pairing of control and unit" [p. 36](#)



## 7.6 Functions

### 7.6.1 Basic menu

#### To access the basic menu

- ▶ with the display off, hold down  for 10 seconds

*The device turns on and  appears*

- ▶ keep pressed until the indication  appears
- ▶ release the  key

*The symbol  appears*

#### To navigate in the menu

- ▶ use the icons  

#### To select a menu item and to confirm the changes made

- ▶ press the icon 

*Confirming the change takes you to the next item.*

#### To exit the menu

- ▶ press the icon  for 10 seconds
- ▶ or wait 30 seconds the automatic shutdown

⚠ After 30 seconds from the last action the control goes out and the settings is memorized.

### Menu items

**ot:** AIR probe offset (air probe setting)

**ur:** Value read by the R.H. sensor

**ut:** Probe Offset PT4

**uS:** Humidity setpoint

**ui:** Humidity hysteresis

**CF:** Scale





**ub:** Buzzer volume

**uu:** Not used

**uP:** Not used

### Set AIR probe offset

#### To set the air probe regulation

- ▶ select 
- ▶ press  to change settings
- ▶ increase or decrease the value with the icons  
- ▶ press  to confirm





*By default it is set to 0.*

*The setting range is from a minimum of -12.0 °C to a maximum of 12.0 °C.*

### Set probe offset RH





⚠ Modify only after real deviations from an actual measurement with professional instrumentation have been established.

#### To set the RH probe regulation

- ▶ select 
- ▶ press  to change settings
- ▶ increase or decrease the value with the icons  
- ▶ press  to confirm





### Set the humidity setpoint

#### To set the humidity setpoint

- ▶ select 
  - ▶ press  to change settings
  - ▶ increase or decrease the value with the icons  
  - ▶ press  to confirm
- The setting range is from 20.0% to 90.0%.*



## Setting the humidity hysteresis

### To set the humidity hysteresis

- ▶ select 
- ▶ press  to change settings
- ▶ increase or decrease the value with the icons  
- ▶ press  to confirm  
*The setting range is from 1 (min) to 30 (max).*

## Scale

### To change the temperature unit of measure





- ▶ select 
- ▶ press  to change settings
- ▶ select °C or °F
- ▶ press  to confirm  
*By default the temperature unit of measure is °C.*

## 7.6.2 Advanced Menu



**⚠** To access the Setup menu, it is necessary to access the Basic menu. See section "Basic menu" p. 34.

The special functions menu can be accessed via the control panel.

### To access the setup menu

- ▶ from the basic menu press 
- Appears 
- ▶ press the  key once
- Appears 
- ▶ press  to confirm and log in  
*This takes you to the settings menu.*



### To navigate in the menu

- ▶ use the icons  

### To select a menu item and to confirm the changes made

- ▶ press  for 2 seconds  
*Confirming the change takes you to the next item.*

### To exit the menu

- ▶ press  for about 10 seconds  
Appears 
- ▶ press  for about 10 seconds  
*The display turns off.*
- ▶ or wait 30 seconds after the last action  
*The display is switched off automatically.*

**⚠** After 30 seconds from the last action the control goes out and the settings is memorized.

## Menu items

**Ad:** Options for ModBus address

**Pr:** Not used





**of:** Options for digital output

**rC:** Radiant cooling options with R20

**rH:** Radiant heating options with R20

## Adjusting the volume

### To change the volume

- ▶ select 
- ▶ press  to change settings
- ▶ increase or decrease the value with the icons  
- ▶ press  to confirm  
*The volume setting range is from 00 (min) to 03 (max).*

**⚠** The volume changes after confirm the modification.

**UC:** Not used









**Ac:** Anti-stratification in cooling

**Ah:** Anti-stratification in heating

**Fr:** Not used



## Set device address for communication

### To set the Modbus address

- ▶ select 
- ▶ press  to change settings
- ▶ press   simultaneously to change the value shown on the display  
*The value shown in the display flashes.*
- ▶ press  to confirm
- ▶ increase or decrease the value with the icons  
- ▶ press  to confirm  
*By default the ModBus address is set to 01.  
The setting range is from 01 (min) to 99 (max).*

## To select digital input

### To change the digital input

- ▶ select 
- ▶ press  to change settings
- ▶ select CP for contact presence (default)
- ▶ select CO to cooling open
- ▶ select CC to cooling close
- ▶ press  to confirm  
*By default digital input is set to CP.*

**⚠** For return to the default settings, set the digital input to "CP".

**⚠** By selecting one of the other inputs (CO,CC) the seasonality is locked. It is not possible to modify it through the key  of the control.

### Set radiant options in heating with R20

- ⚠ To change the rH function, it is necessary to have the accessory MZS - Single zone module for radiant system, code EG1028II.
- ⚠ To change the settings, please refer to the Instruction Sheet of the accessory MZS - Single zone module for radiant system, code EG1028II.





### Set radiant options to cooling with R20

- ⚠ To change the rC function, it is necessary to have the accessory MZS - Single zone module for radiant system, code EG1028II.
- ⚠ To change the settings, please refer to the Instruction Sheet of the accessory MZS - Single zone module for radiant system, code EG1028II.

### Set the anti-stratification function to cooling

#### To set the anti-stratification function in cooling mode







- ▶ select 
- ▶ press  to change settings  
*Appears *

- ▶ press  to move within the menu
- ▶ select  to enable the function
- ▶ press  to confirm changes  
*By default, the anti-stratification function in cooling is set to *

- ⚠ The anti-stratification function in cooling is to be set for appliances installed at low floor level equipped with an active air probe.

### Set the anti-stratification function in heating mode

#### To set the anti-stratification function in heating mode



- ▶ select 
- ▶ press  to change settings  
*Appears *
- ▶ press  to move within the menu
- ▶ select  to enable the function
- ▶ press  to confirm changes  
*By default, the anti-stratification function in heating is set to *

- ⚠ The anti-stratification function in heating is to be set for appliances installed high up on the wall or ceiling equipped with an active air sensor.

## 7.6.3 Pairing of control and unit

- ⚠ The matching procedure between control and luminaire is mandatory in case of a connection between several luminaires.

#### To pair the control with the unit

- ▶ with control switched on, at the same time press  and  for about 10 seconds  
*In the display area, where the setpoint is indicated, appears the number of connected devices. The displayed value flashes.*

1. Red LED
2. Green LED
3. Black button
4. Electrical box

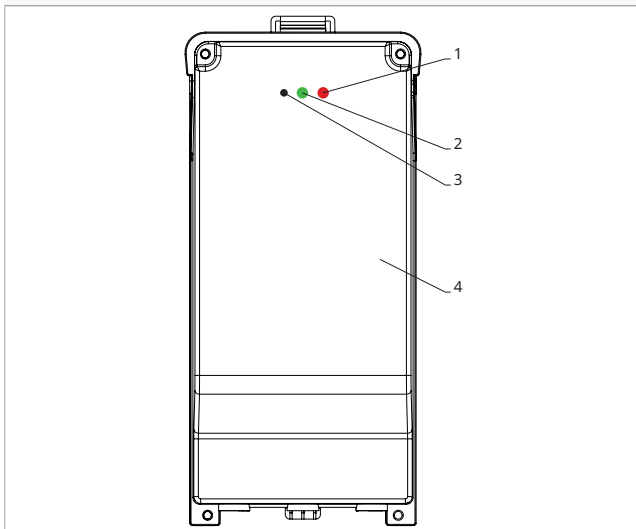

#### On the electrical box on the unit

- ▶ press the black button for 3 seconds  
*The green LED flashes.  
The red LED is on.*
- ▶ wait for the procedure to complete  
*The green LED stops flashing.*





#### On the wall mounted control panel

- ▶ *Appear the number assigned to the fancoil.  
Then appears the number of connected devices.*
- ▶ press  to exit the menu





### Reset pairing

- ⚠ To reset the pairing settings, it is first necessary to access the "Basic menu" [p. 34](#).



#### To reset pairing settings

- ▶ access the basic menu
- ▶ press 
- ▶ press   
*All the way to the  menu.*
- ▶ press 



#### To reset a single fancoil

- ▶ *Appears *
- ▶ press   
*Appears *
- ▶ press  to access the menu
- ▶ use the  icons to move inside the menu  
*The assignment numbers assigned to the fancoils appear.*









- ▶ select the fancoil to be reset
- ▶ press  to confirm
- ▶  appears, with an acoustic signal.  
The device is removed.

#### To exit the setting

- ▶ press  for 5 seconds
- ▶ Exit the  setting.  
Back to menu 02.

#### To reset all fancoils

- ▶ Appears 
- ▶ press  until  appears
- ▶ Appears 
- ▶ press  to access the menu
- ▶ use the  icons to move inside the menu
- ▶ select No to maintain all fancoils
- ▶ select Yes to reset the fancoils
- ▶ press  to confirm

## LED interface operation on the electrical box

#### If the device is being paired

The green LED flashes.

#### If the device is paired and functioning

The green LED is on.

#### If the device has not been paired and is not functional

The green LED is off.  
The red LED is on.

#### If the device is in alarm status

The red LED flashes.

- ▶  The red LED flashes according to the type of alarm. To check the alarm type, please refer to the following "Error signals" [p. 37](#) section.

#### If communication with the board is missing

The green and red LEDs will flash once every second.

## 7.6.4 Error signals

The PCB has a status LED.

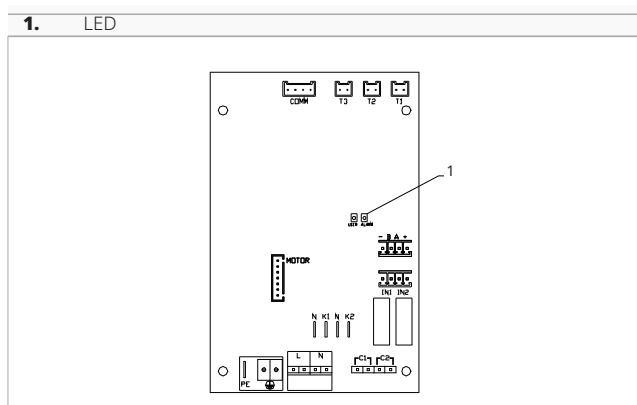

- ▶  Once the pairing has been completed, the red LED on the cover of the electrical box performs the same functions as the LED on the board on the unit.

- ▶  The flashing LED indicates errors.



- ▶  With the LED on, it is indicated that there aren't errors.

#### LED signals

- ▶ Led flashing  
Errors to be shown on the display.
- ▶ LED off  
Comando a muro spento  
LED on  
Wall control on and no alarm present.
- ▶ LED continuous flashing with pause between flashes  
Unsuitable water temperature alarm.
- ▶ LED 2 flashes / pause  
Internal fan motor alarm faulty or disconnected.
- ▶ LED 3 flashes / pause  
Alarm for water temperature probe H2/T2 disconnected or faulty.
- ▶ LED 6 flashes / pause  
Communication error alarm with wall control panel.





## 7.6.5 Alarm display on wall control panel

- ▶  In the event of an alarm, the device still maintains active functions.

- ▶  The symbol  is displayed on the wall control panel to indicate alarms.

- ▶  To access the Setup menu, it is necessary to access the Basic menu. See section "Basic menu" [p. 34](#).

#### To visualise errors on the wall control panel

- ▶ access the basic menu
- ▶ press 
- ▶ Appears 
- ▶ press 
- ▶ Appears 
- ▶ press  to confirm
- ▶ Then the number assigned to the fancoil appears and then the error is displayed.

#### Displayed alarms

- ▶ E2 Faulty internal fan motor or disconnected  
None of the modes can be activated.
- ▶ E3 Water temperature probe H2/T2 disconnected or failure  
None of the modes can be activated.
- ▶ E8 Communication error  
Communication error between the wall control panel and the fancoil or in case of combining multiple appliances.
- ▶ h2o Incorrect water temperature  
In heating mode, the water temperature is below 30 °C.  
In cooling mode, the water temperature is above 20 °C.

- ▶  Error E8 is displayed without the error display procedure on the wall control panel.

## M7 SERIES CONTROL PART NO. EFB749

### 8.1 Interface

1. Display area
2. Keys area

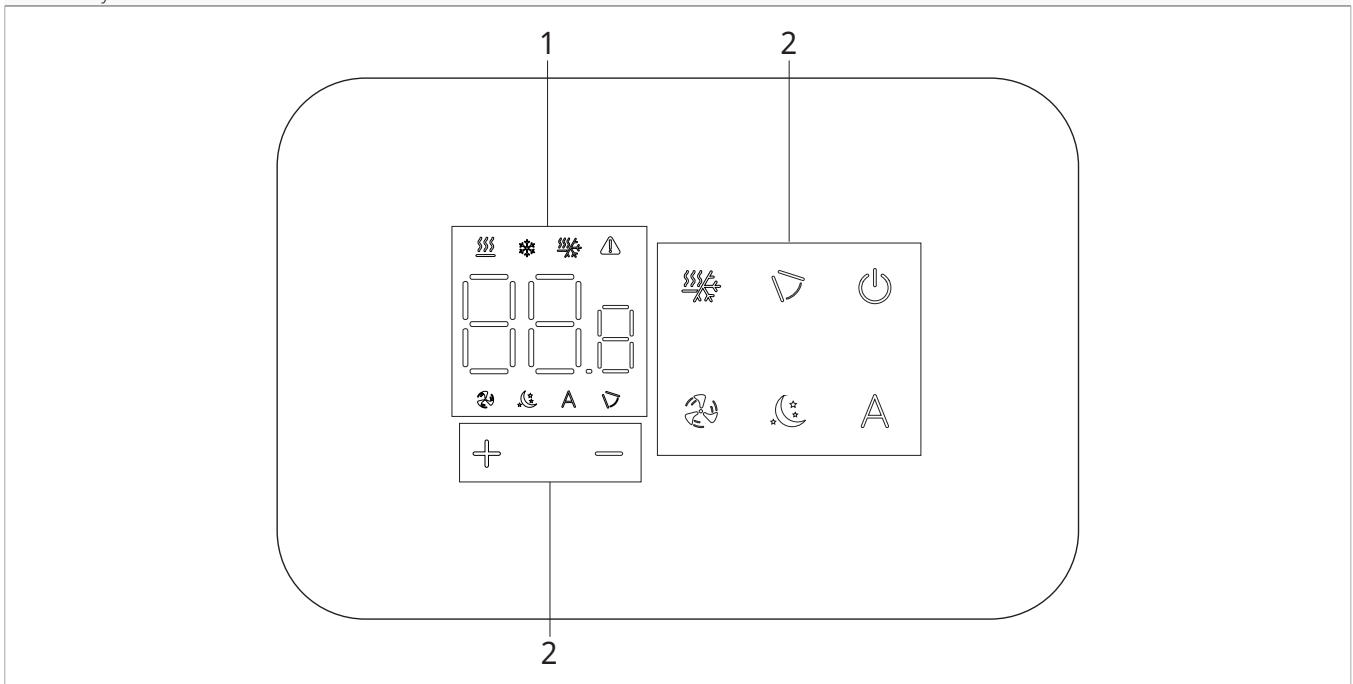

### 8.2 Installation

#### 8.2.1 Description

the wall-mounted remote control is an electronic LED thermostat with a touch interface, with the possibility of control over multiple appliances equipped with the same electronic board. It is equipped with a temperature and humidity probe.

- ⚠ The control can control up to a maximum of 16 units.
- ⚠ For wall control code EFB749, the app is available.

#### 8.2.2 Mounting

- ⚠ The control panel for wall control is to be installed inside a 503 electrical box.
- ⚠ A wall must be prepared to accommodate the 503 electrical box before installing the wall control.
- ⚠ Ensure that:
  - the wall supports the weight of the appliance
  - the section of floor or wall does not concern piping or electrical lines
  - the functionality of load-bearing elements is not compromised

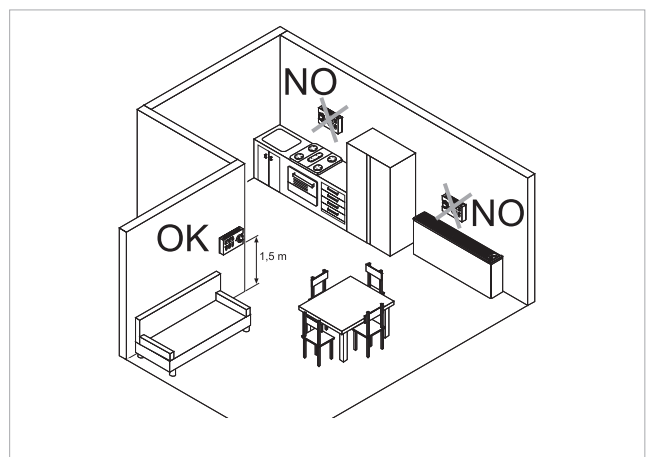

The wall-mounted remote control must be installed:

- on internal walls
- at a height of about 1,5 m from the floor
- away from doors or windows
- away from heat sources (heaters, convectors, stoves, direct sunlight)

⚠ The wall control is provided inside the package already assembled.

- |    |                            |
|----|----------------------------|
| 1. | Base of control            |
| 2. | Wall-mounted control panel |

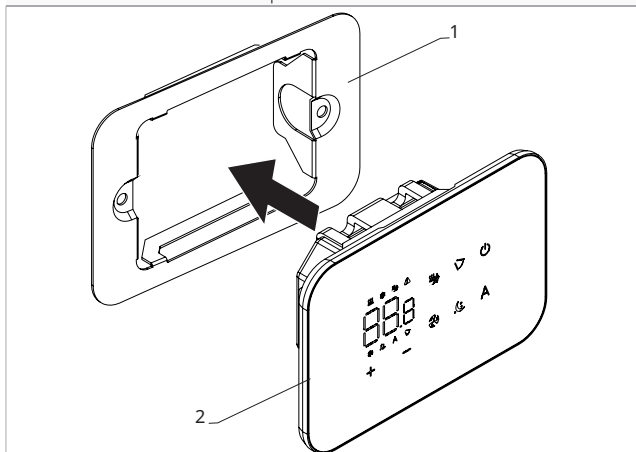

**Before wall installation:**

- ▶ separate the control base from the control panel

- |    |                                    |
|----|------------------------------------|
| 1. | Fixing screws                      |
| 2. | Base of control                    |
| 3. | Holes for fixing to electrical box |
| 4. | Electric box 503                   |

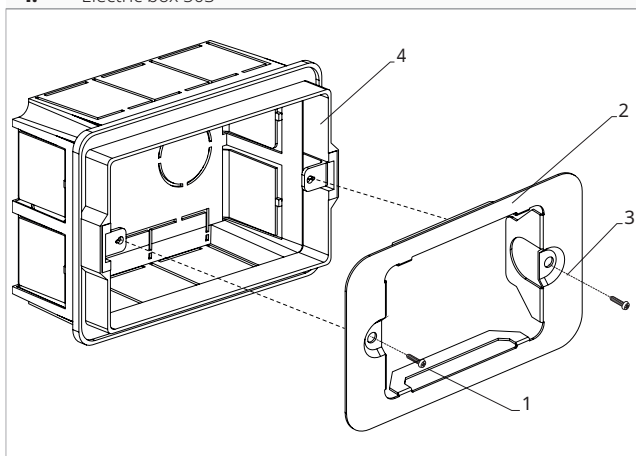

**For wall mounting of the control panel:**

- ▶ fix the control base to the electrical box 503 with screws
- ▶ connect the electrics

⚠ Before making the connections, please verify that the control terminal block is on the right-hand side.

- |    |                            |
|----|----------------------------|
| 1. | Electric box 503           |
| 2. | Base of control            |
| 3. | Wall-mounted control panel |

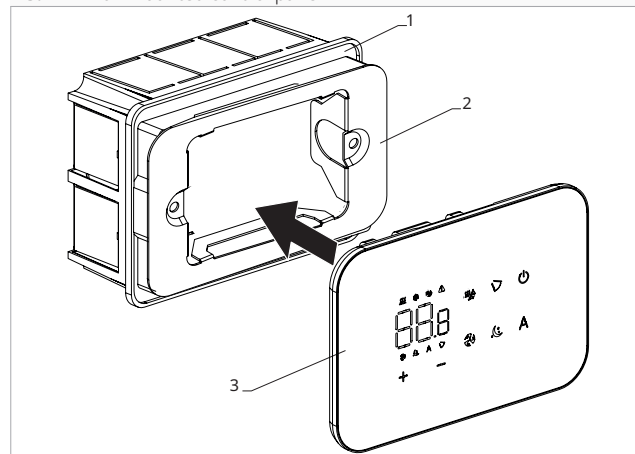

- ▶ Close the control panel

⚠ Pay attention not to crush the conductors when you close the control.

### 8.3 Single connection diagram

<b>M1</b>	Fan motor DC Inverter
<b>PE</b>	Earth connection
<b>L-N</b>	Power supply connection 230 V / 50 Hz / 1 A
<b>Y1</b>	Water electrovalve (voltage output 230 V / 50 Hz / 1 A)
<b>CH/C1</b>	Cooling request contact (for example chiller or reversible heat pump). Activated in parallel with the solenoid valve output (Y1) with 1 minute delay when the fancoil is in cooling mode and is on call (potential-free contact max. 1 A).
<b>BO/C2</b>	Heating request contact (for example boiler or heat pump). Activated in parallel with the output of the solenoid valve (Y1)

<b>CP</b>	Presence contact (normally open)
<b>-BA+</b>	Serial connection for wall-mounted remote control (respect polarisation AB)
<b>IN1</b>	Potential-free input 1(not active)
<b>H2/T2</b>	2-pipe water temperature probe
<b>LU</b>	Electronic board for pairing control and device
<b>PU</b>	Electronic board on the unit
<b>M7</b>	wall-mounted control series M7

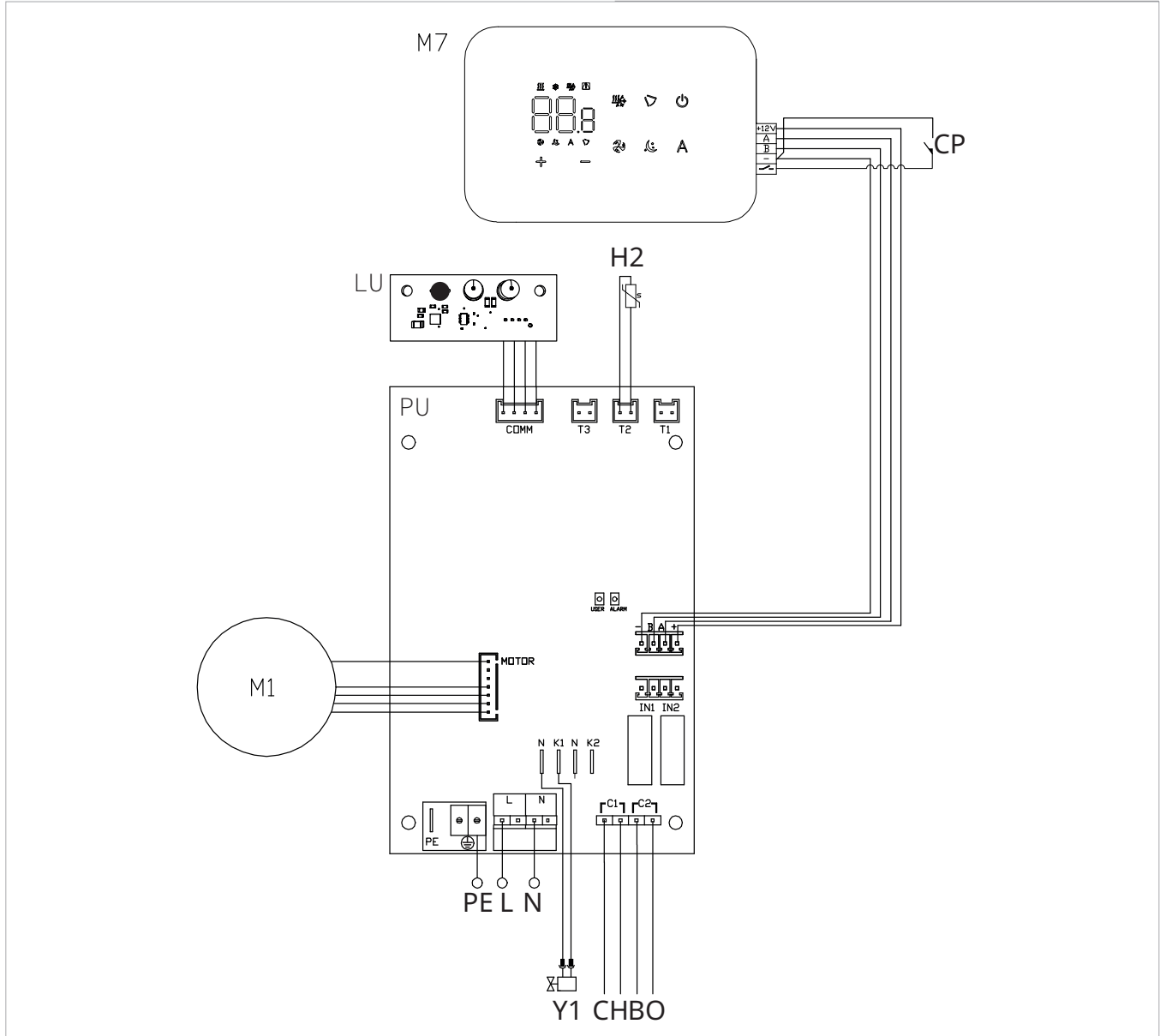

⚠ For wall control code EFB749, the app is available.



## 8.5 Connections

### 8.5.1 Preliminary warnings

⚠ The terminals for connecting the control panel and the presence contact CP are placed in a plastic bag and positioned inside the cover of the electrical box.

1. Terminal blocks

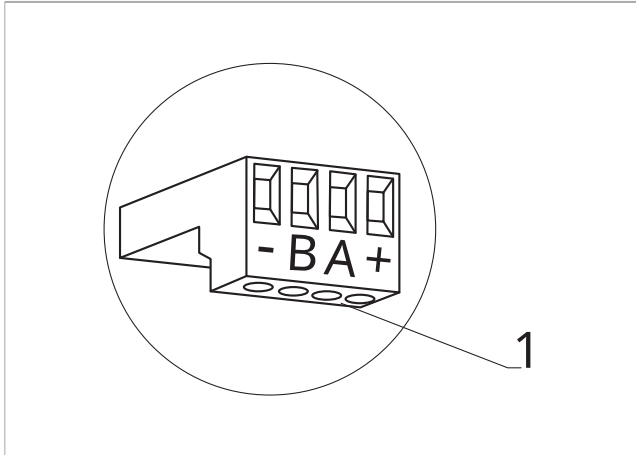

#### The terminals accept:

- rigid or flexible wires with a 0.2 to 1 mm<sup>2</sup> cross-section
- rigid or flexible wires with 0,5 mm<sup>2</sup> cross-section if two wires are connected to the same terminal block
- rigid or flexible wires with 0,75 mm<sup>2</sup> cross-section if the wires have wire end ferrules with a plastic collar

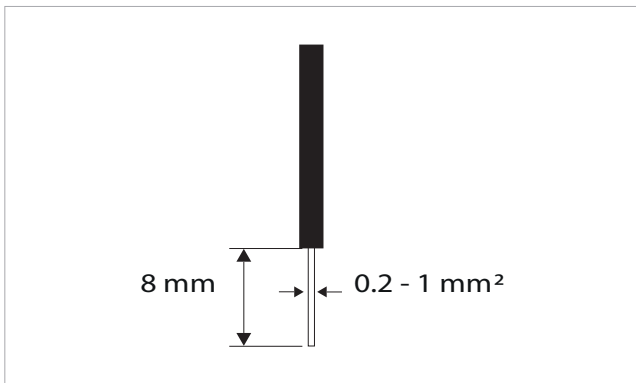

#### To connect the cables:

- ▶ strip 8 mm of the wire
- ▶ if the wire is rigid, you can insert it easily whereas
- ▶ if it is flexible, use appropriate crimp terminals
- ▶ push the wire completely in
- ▶ check the right fixing by pulling it gently

### 8.5.2 Control Panel

⚠ The control panel for wall control must be ordered separately.

#### Terminal block position:

1. Terminal block ( Back view panel)

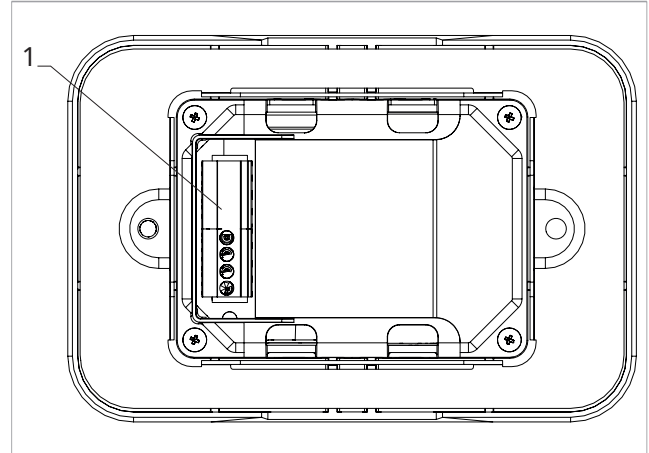

1. Terminal blocks

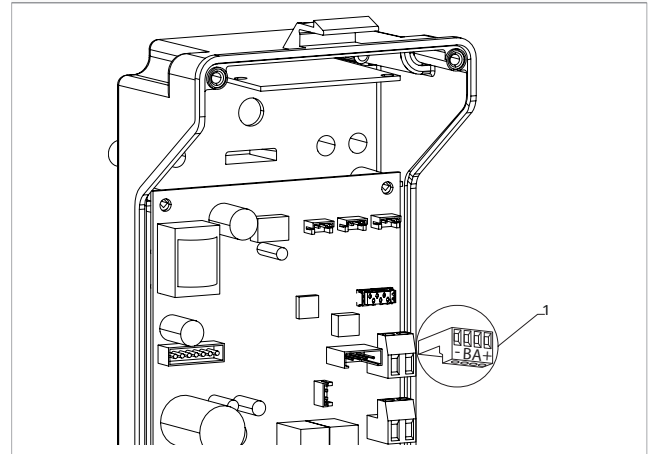

#### To connect the wall control panel to the board:

- ▶ connect the power supply cables to the + - terminals
- ▶ connect the ModBus serial connection cables to terminals A and B

### 8.5.3 Presence contact CP

Trough this contact it is possible connect an external device that inhibits the operation of the device, for example:

- opening window contact
- remote on/off
- infrared presence sensor
- enabling badge
- remote change of season

#### Function

*The contact is normally open.*

- ▶ when closing the CP contact, connected to a potential-free contact, the device switches to stand-by mode  
*CP appears on the display.*
- ▶ At the touch of a button on the display the symbol ⚠ flashes.

⊖ It is forbidden connect in parallel the CP input to one of another electronic board. Use separate contacts.

The CP presence contact can be configured for heating and cooling operation via the "To select digital input" [p. 45](#) settings menu item (digital input).

### 8.5.4 RS485 Serial Connection

The wall-mounted remote control can be connected through a RS485 serial line to one or more device, for a maximum of 16.

The devices must be equipped with an electronic board suitable for remote control.

For the connection:

- ▶ follow the indication on the connection diagram
- ▶ connect respecting the indication A and B

- ⚠ Use a bipolar shielded cable suitable for the RS485 serial connection with a minimum section of 0,35 mm<sup>2</sup>.
- ⚠ Keeping the bipolar cable separate from power supply cables.
- ⚠ Chase out the wall in order to minimize the length of the leads.
- ⚠ Complete the line with the 120 Ω resistance.
- ⊖ It is forbidden make star connections.
- ⚠ In the case of a connection between multiple devices, it is mandatory to pair the control with the device. See paragraph "Pairing of control and unit" [p. 45](#)



## 8.6 Functions

### 8.6.1 Basic menu

#### To access the basic menu



- ▶ with the display off, hold down  for 10 seconds

*The device turns on and  appears*

- ▶ keep pressed until the indication  appears
- ▶ release the  key

*The symbol  appears*

#### To navigate in the menu

- ▶ use the icons  

#### To select a menu item and to confirm the changes made

- ▶ press the icon 
- Confirming the change takes you to the next item.*

#### To exit the menu

- ▶ press the icon  for 10 seconds
- ▶ or wait 30 seconds the automatic shutdown

⚠ After 30 seconds from the last action the control goes out and the settings is memorized.

### Menu items

**ot:** AIR probe offset (air probe setting)

**ur:** Value read by the R.H. sensor

**ut:** Probe Offset PT4

**uS:** Humidity setpoint

**ui:** Humidity hysteresis

**CF:** Scale





**ub:** Buzzer volume

**uu:** Wi-Fi reset

**uP:** Wi-Fi pairing

### Set AIR probe offset





#### To set the air probe regulation

- ▶ select 
  - ▶ press  to change settings
  - ▶ increase or decrease the value with the icons  
  - ▶ press  to confirm
- By default it is set to 0.  
The setting range is from a minimum of -12.0 °C to a maximum of 12.0 °C.*

### Set probe offset RH





**⚠** Modify only after real deviations from an actual measurement with professional instrumentation have been established.

#### To set the RH probe regulation

- ▶ select 
- ▶ press  to change settings
- ▶ increase or decrease the value with the icons  
- ▶ press  to confirm





### Set the humidity setpoint

#### To set the humidity setpoint

- ▶ select 
- ▶ press  to change settings
- ▶ increase or decrease the value with the icons  
- ▶ press  to confirm  
*The setting range is from 20.0% to 90.0%.*



### Setting the humidity hysteresis

#### To set the humidity hysteresis

- ▶ select 
- ▶ press  to change settings
- ▶ increase or decrease the value with the icons  
- ▶ press  to confirm  
*The setting range is from 1 (min) to 30 (max).*

### Scale

#### To change the temperature unit of measure





- ▶ select 
- ▶ press  to change settings
- ▶ select °C o °F
- ▶ press  to confirm  
*By default the temperature unit of measure is ° C.*

## 8.6.2 Advanced Menu

**⚠** To access the Setup menu, it is necessary to access the Basic menu. See section "Basic menu" p. 43.





The special functions menu can be accessed via the control panel.

#### To access the setup menu

- ▶ from the basic menu press 
- ▶ appears 
- ▶ press the  key once
- ▶ appears 
- ▶ press  to confirm and log in  
*The advanced menu is accessed.*

### Adjusting the volume









#### To change the volume

- ▶ select 
- ▶ press  to change settings
- ▶ increase or decrease the value with the icons  
- ▶ press  to confirm  
*The volume setting range is from 00 (min) to 03 (max).*

**⚠** The volume changes after confirm the modification.









### Wi-Fi reset

#### To reset the Wi-Fi credentials and return the device to its original configuration

- ▶ select 
- ▶ press  to change settings
- ▶ use the   icons in sequence  
*Appears *
- ▶ press 
- ▶   appears to reset Wi-Fi credentials.
- ▶ press  to confirm  
*Credentials have been reset.*



### Activate Wi-Fi

#### To activate Wi-Fi

- ▶ select 
- ▶ press  to change settings
- ▶ use the   icons in sequence  
*Appears *
- ▶ press 
- ▶   appears to enable Wi-Fi pairing.
- ▶ press  to confirm

**⚠** The device remains visible on the App for the first 15 minutes after the device is switched on.



#### To navigate in the menu

- ▶ use the icons  

#### To select a menu item and to confirm the changes made

- ▶ press  for 2 seconds  
*Confirming the change takes you to the next item.*

#### To exit the menu

- ▶ press  for about 10 seconds  
*Appears *
- ▶ press  for about 10 seconds  
*The display turns off.*
- ▶ or wait 30 seconds after the last action  
*The display is switched off automatically.*

**⚠** After 30 seconds from the last action the control goes out and the settings is memorized.



## Menu items

**Ad:** Not used

**Pr:** Not used

**of:** Options for digital output

**rH:** Radiant heating options with R20

**rC:** Radiant cooling options with R20

**UC:** Not used

**Ac:** Anti-stratification in cooling



**Ah:** Anti-stratification in heating

**Ed:** Not used

**Fr:** Not used

## To select digital input

### To change the digital input

- ▶ select 
  - ▶ press  to change settings
  - ▶ select CP for contact presence (default)
  - ▶ select CO to cooling open
  - ▶ select CC to cooling close
  - ▶ press  to confirm
- By default digital input is set to CP.*

⚠ For return to the default settings, set the digital input to "CP".

⚠ By selecting one of the other inputs (CO,CC) the seasonality is locked. It is not possible to modify it through the key  of the control.

## Set radiant options in heating with R20

⚠ To change the rH function, it is necessary to have the accessory MZS - Single zone module for radiant system, code EG1028II.

⚠ To change the settings, please refer to the Instruction Sheet of the accessory MZS - Single zone module for radiant system, code EG1028II.







## Set radiant options to cooling with R20

⚠ To change the rC function, it is necessary to have the accessory MZS - Single zone module for radiant system, code EG1028II.

⚠ To change the settings, please refer to the Instruction Sheet of the accessory MZS - Single zone module for radiant system, code EG1028II.

## Set the anti-stratification function to cooling







### To set the anti-stratification function in cooling mode

- ▶ select 
- ▶ press  to change settings  
*Appears .*
- ▶ press  to move within the menu
- ▶ select  to enable the function
- ▶ press  to confirm changes  
*By default, the anti-stratification function in cooling is set to .*

⚠ The anti-stratification function in cooling is to be set for appliances installed at low floor level equipped with an active air probe.

## Set the anti-stratification function in heating mode

### To set the anti-stratification function in heating mode



- ▶ select 
- ▶ press  to change settings  
*Appears .*
- ▶ press  to move within the menu
- ▶ select  to enable the function
- ▶ press  to confirm changes  
*By default, the anti-stratification function in heating is set to .*

⚠ The anti-stratification function in heating is to be set for appliances installed high up on the wall or ceiling equipped with an active air sensor.

## 8.6.3 Pairing of control and unit

⚠ The pairing procedure between the control and the device is mandatory in case of a connection between multiple devices.

### To pair the control with the unit

- ▶ with control switched on, at the same time press  and  for about 10 seconds
- In the display area, where the setpoint is indicated, appears the number of connected devices.  
The displayed value flashes.*

1. Red LED
2. Green LED
3. Black button
4. Electrical box

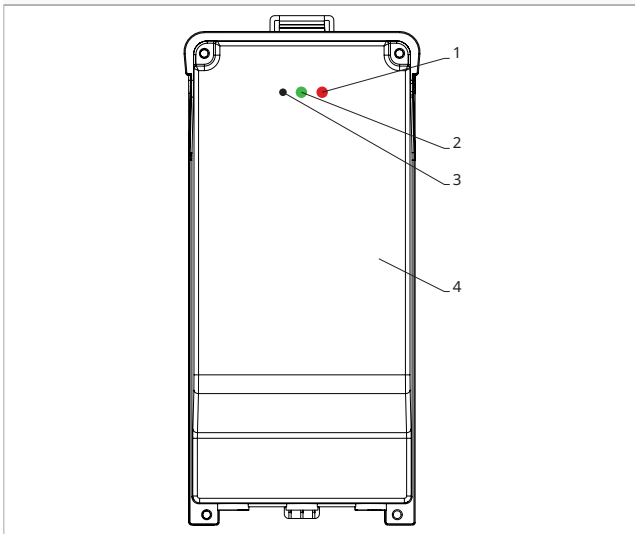

**On the electrical box on the unit**

- ▶ press the black button for 3 seconds  
*The green LED flashes.  
The red LED is on.*
- ▶ wait for the procedure to complete  
*The green LED stops flashing.*

**On the wall mounted control panel**

*Appear the number assigned to the fancoil.  
Then appears the number of connected devices.*

- ▶ press to exit the menu

**⚠ To reset the pairing settings, it is first necessary to access the basic menu. See section "Basic menu" p. 43.**

**To reset pairing settings**

- ▶ access the basic menu
- ▶ press
- ▶ press
- All the way to the menu.*
- ▶ press

**To reset a single fancoil**

*Appears*

- ▶ press
- Appears*
- ▶ press to log in
- ▶ use the icons to move inside the menu  
*The assignment numbers assigned to the fancoils appear.*
- ▶ select the fancoil to be reset
- ▶ press to confirm  
 appears, with an acoustic signal.  
*The device is removed.*

**To exit the setting**

- ▶ press for 5 seconds  
*Exit the setting.  
Back to menu 02.*

**To reset all fancoils**

*Appears*

- ▶ press until appears  
*Appears .*
- ▶ press to confirm
- ▶ use the icons to move inside the menu
- ▶ select No to maintain all fancoils
- ▶ select Yes to reset the fancoils
- ▶ press to confirm

**LED interface operation on the electrical box**

**If the device is being paired**

*The green LED flashes.*

**If the device is paired and functioning**

*The green LED is on.*

**If the device has not been paired and is not functional**

*The green LED is off.  
The red LED is on.*

**If the device is in alarm status**

*The red LED flashes.*

**⚠** The red LED flashes according to the type of alarm. To check the alarm type, please refer to the following "Error signals" p. 46 section.

**If communication with the board is missing**

*The green and red LEDs will flash once every second.*

**8.6.4 Error signals**

The PCB has a status LED.

1. LED

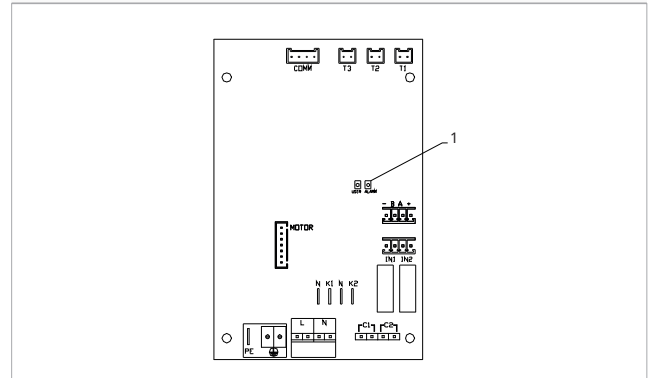

**⚠** The LED on the cover of the electrical box performs the same functions as the LED on the machine board.

**⚠** The flashing LED indicates errors.

**⚠** With the LED on and no indication on the display, it is indicated that there are no errors.

**LED signals**

- ▶ Led flashing  
*Errors to be shown on the display.*
- ▶ LED off  
*Remote control switched off.*
- ▶ LED continuous flashing with pause between flashes  
*Unsuitable water temperature alarm.*

- ▶ LED on  
*Wall control on and no alarm present.*
- ▶ LED 2 flashes / pause  
*Internal fan motor alarm faulty or disconnected.*
- ▶ LED 3 flashes / pause  
*Alarm for water temperature probe H2/T2 disconnected or faulty.*
- ▶ LED 6 flashes / pause  
*Communication error alarm with wall control panel.*





### 8.6.5 Alarm display on wall control panel

⚠ In the event of an alarm, the device still maintains active functions.

⚠ The symbol  is displayed on the wall control panel to indicate alarms.

⚠ **To access the Setup menu, it is necessary to access the Basic menu. See section "Basic menu" p. 43.**

#### To visualise errors on the wall control panel

- ▶ access the basic menu
- ▶ press   
*Appears .*
- ▶ press   
*Appears .*  
*Then the number assigned to the fancoil appears and then the error is displayed.*

#### Displayed alarms

- ▶ E2 Faulty internal fan motor or disconnected  
*None of the modes can be activated.*
- ▶ E3 Water temperature probe H2/T2 disconnected or failure  
*None of the modes can be activated.*
- ▶ E5 H4/T3 heating water probe disconnected or faulty  
*None of the modes can be activated.*
- ▶ E6 Incorrect water temperature with automatic season function setting  
*The fancoil is performing heating and cooling functions incorrectly. None of the unit's functions can be activated.*
- ▶ E8 Communication error  
*Communication error between the wall control panel and the fan coil or in case of pairing between multiple devices.*
- ▶ h2o Incorrect water temperature  
*In heating mode, the water temperature is below 30 °C.  
In cooling mode, the water temperature is above 20 °C.*

⚠ Error E8 is displayed without the error display procedure on the wall control panel.

# M7 SERIES CONTROL CODE EGB749

## 9.1 Interface

- 1. Display area
- 2. Keys area

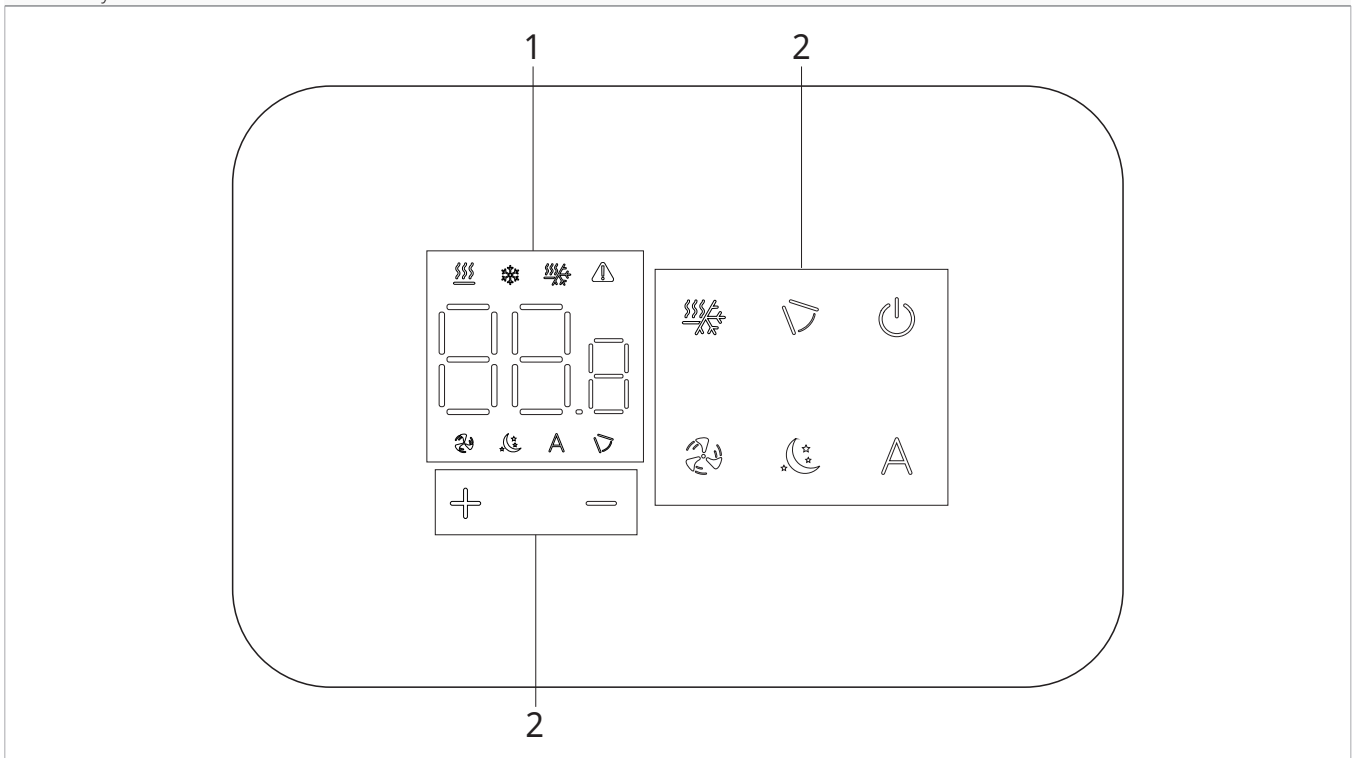

## 9.2 Installation

### 9.2.1 Description

the wall-mounted remote control is an electronic LED thermostat with a touch interface, with the possibility of control over multiple appliances equipped with the same electronic board. It is equipped with a temperature and humidity probe.

⚠ The control can control up to a maximum of 16 units.

### 9.2.2 Mounting

⚠ The control panel for wall control is to be installed inside a 503 electrical box.

⚠ A wall must be prepared to accommodate the 503 electrical box before installing the wall control.

⚠ Ensure that:

- the wall supports the weight of the appliance
- the section of floor or wall does not concern piping or electrical lines

- the functionality of load-bearing elements is not compromised

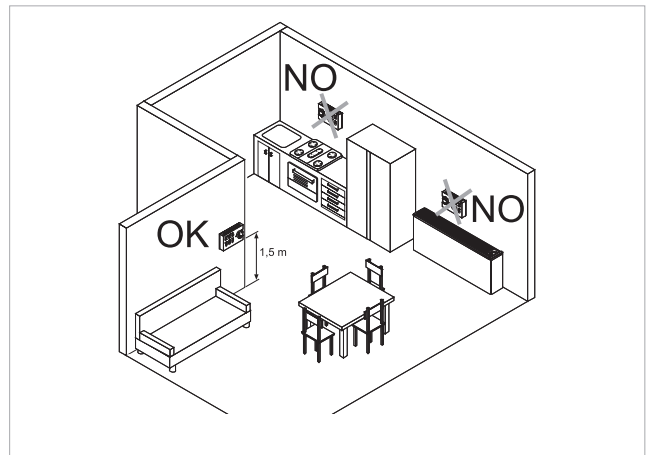

The wall-mounted remote control must be installed:

- on internal walls

- at a height of about 1,5 m from the floor
- away from doors or windows
- away from heat sources (heaters, convectors, stoves, direct sunlight)

⚠ The wall control is provided inside the package already assembled.

- |    |                            |
|----|----------------------------|
| 1. | Base of control            |
| 2. | Wall-mounted control panel |

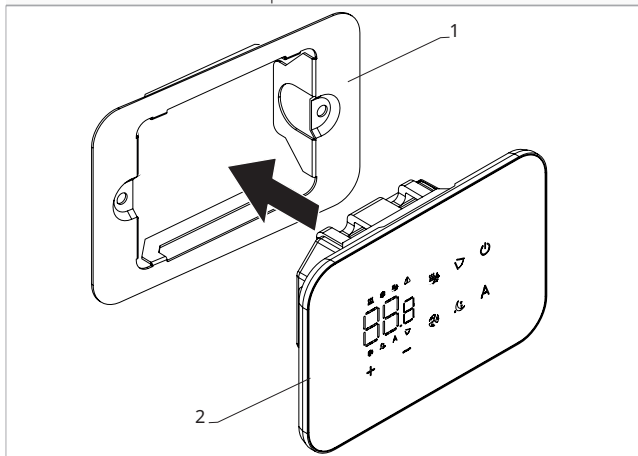

- |    |                            |
|----|----------------------------|
| 1. | Electric box 503           |
| 2. | Base of control            |
| 3. | Wall-mounted control panel |

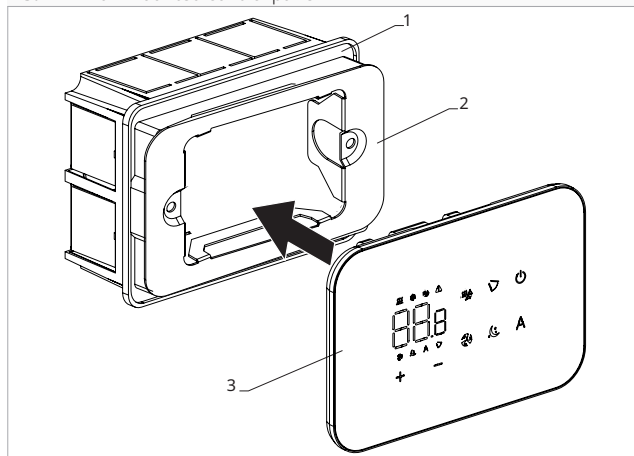

▶ Close the control panel

⚠ Pay attention not to crush the conductors when you close the control.

**Before wall installation:**

- ▶ separate the base of the control consisting of a plate from the control panel

- |    |                                    |
|----|------------------------------------|
| 1. | Fixing screws                      |
| 2. | Base of control                    |
| 3. | Holes for fixing to electrical box |
| 4. | Electric box 503                   |

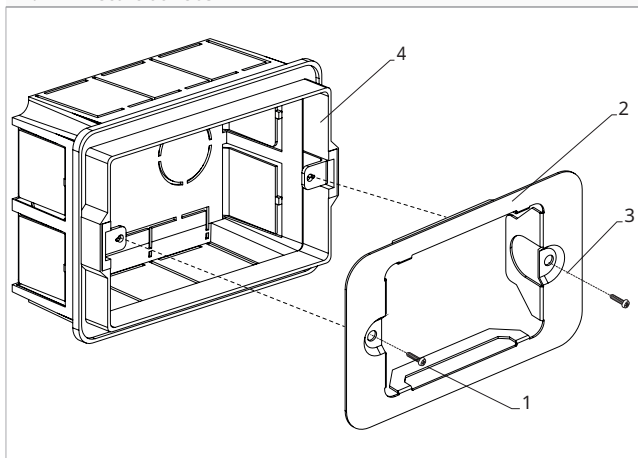

**For wall mounting of the control panel:**

- ▶ fix the control base to the electrical box 503 with screws
- ▶ connect the electrics

⚠ Before making the connections, please verify that the control terminal block is on the right-hand side.

### 9.3 Single connection diagram

<b>M1</b>	Fan motor DC Inverter
<b>PE</b>	Earth connection
<b>L-N</b>	Power supply connection 230 V / 50 Hz / 1 A
<b>Y1</b>	Water electrovalve (voltage output 230 V / 50 Hz / 1 A)
<b>CH/C1</b>	Cooling request contact (for example chiller or reversible heat pump). Activated in parallel with the solenoid valve output (Y1) with 1 minute delay when the fancoil is in cooling mode and is on call (potential-free contact max. 1 A).
<b>BO/C2</b>	Heating request contact (for example boiler or heat pump). Activated in parallel with the output of the solenoid valve (Y1)

<b>IN1</b>	Potential-free input 1(not active)
<b>H2/T2</b>	2-pipe water temperature probe
<b>CP</b>	Presence contact (normally open)
<b>LU</b>	Electronic board for pairing control and device
<b>PU</b>	Electronic board on the unit
<b>BT</b>	Bluetooth communication card
<b>M7</b>	M7 series wall control command

with 1 minute delay when the fancoil is in heating mode and is on call (potential-free contact max. 1 A).

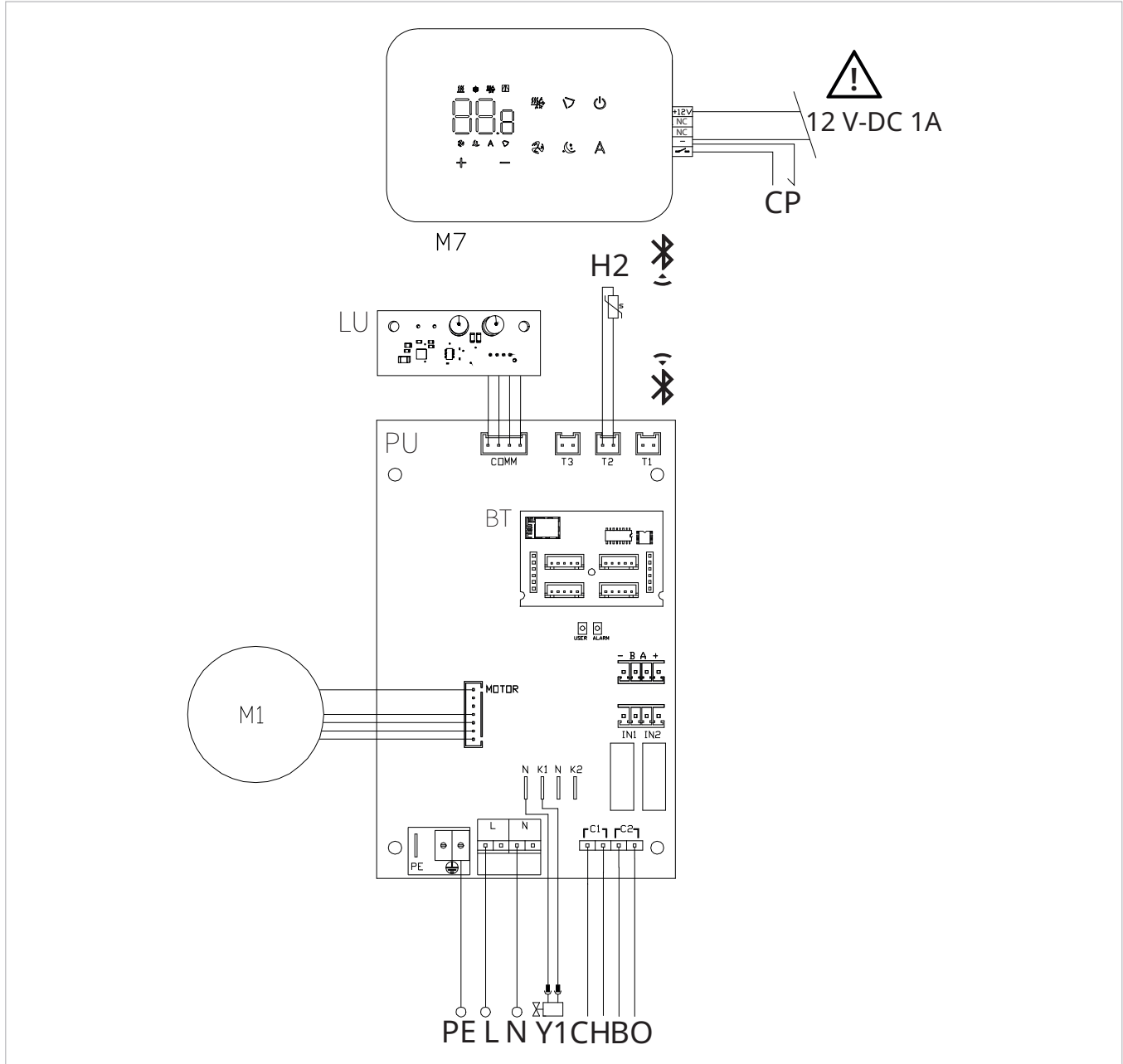

**⚠ It is possible to power the control unit either via a separate 12 V-DC 1A power supply (not supplied) or by connection to the - + contacts on the board.**

**⚠ The matching procedure between command and device is mandatory. See section "Pairing of control and unit" [p. 55](#)**

## 9.4 Multiple connection diagram

- |    |                                      |    |                                      |
|----|--------------------------------------|----|--------------------------------------|
| 1. | M7 series wall control panel         | 3. | PCB                                  |
| 2. | Terminal block for device connection | 4. | Board for pairing control and device |

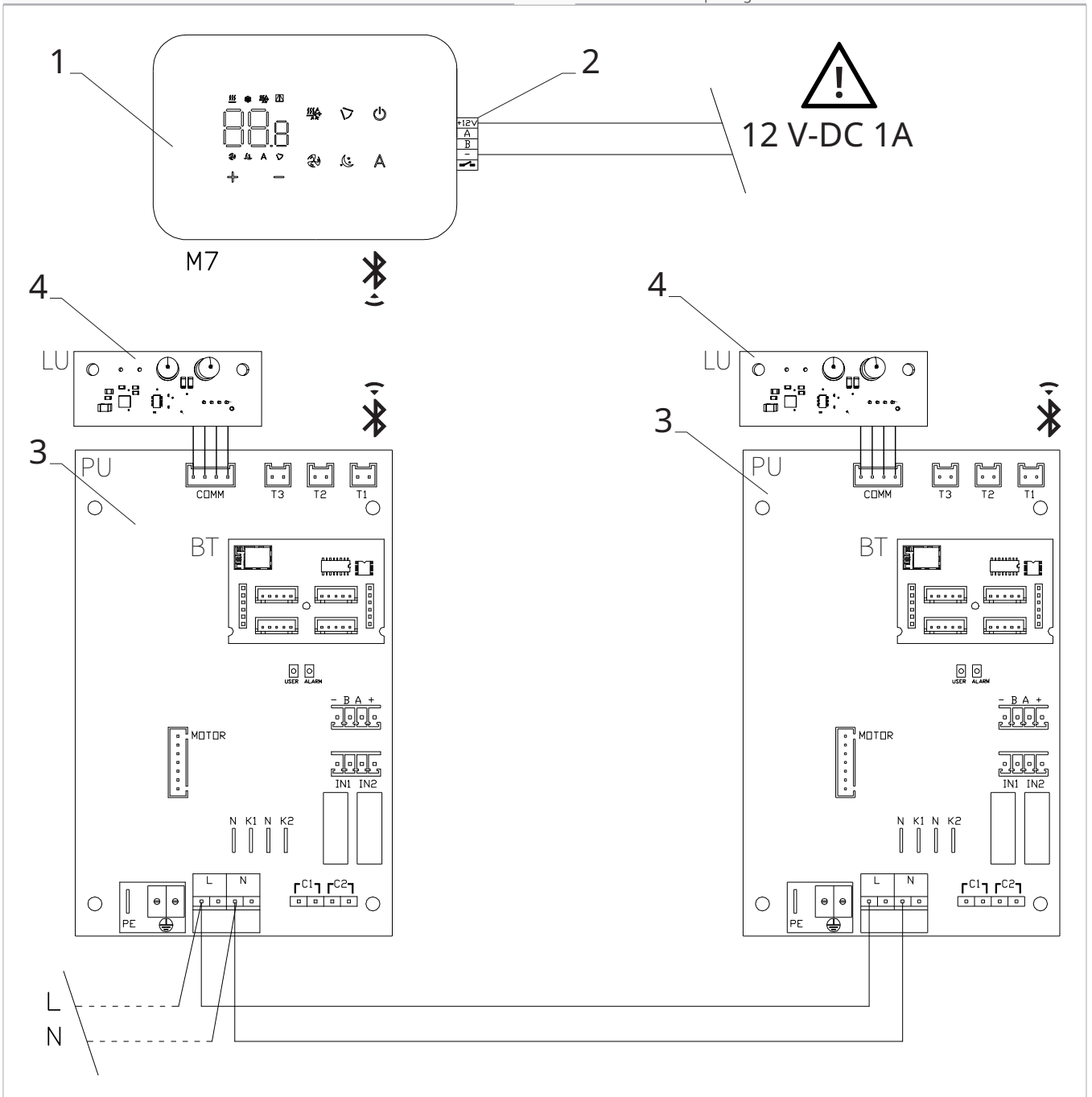

⚠ It is possible to power the control unit either via a separate 12 V-DC power supply (not supplied) or by connection to the - + contacts on the PU board.

⚠ The matching procedure between command and device is mandatory. See section "Pairing of control and unit" [p. 55](#).

## 9.5 Connections

### 9.5.1 Preliminary warnings

⚠ The terminals for connecting the control panel and the presence contact CP are placed in a plastic bag and positioned inside the cover of the electrical box.

1. Terminal blocks

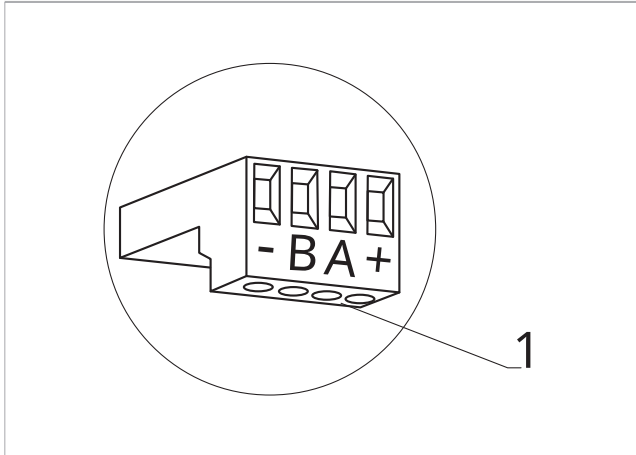

#### The terminals accept:

- rigid or flexible wires with a 0.2 to 1 mm<sup>2</sup> cross-section
- rigid or flexible wires with 0,5 mm<sup>2</sup> cross-section if two wires are connected to the same terminal block
- rigid or flexible wires with 0,75 mm<sup>2</sup> cross-section if the wires have wire end ferrules with a plastic collar

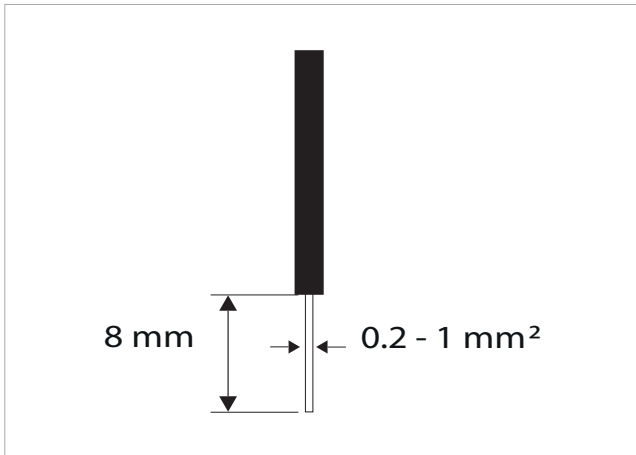

#### To connect the cables:

- ▶ strip the wire
- ▶ if the wire is rigid, you can insert it easily whereas
- ▶ if it is flexible, use appropriate crimp terminals
- ▶ push the wire completely in
- ▶ check the right fixing by pulling it gently

### 9.5.2 Control Panel

⚠ The control panel for wall control must be ordered separately.

#### Terminal block position:

1. Terminal block ( Back view panel)

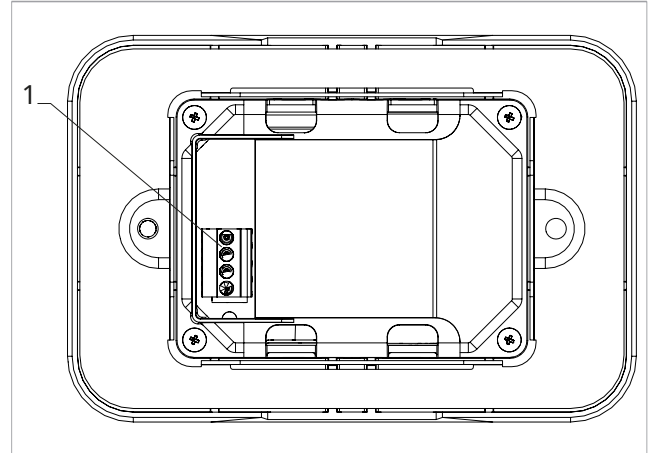

1. Terminal blocks

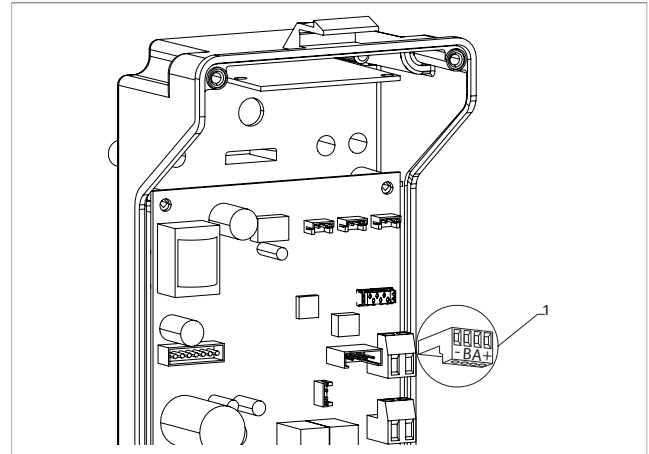

#### To connect the wall control panel to the board:

- ▶ connect the power supply cables to a 12 V-dc power supply

### 9.5.3 Presence contact CP

Trough this contact it is possible connect an external device that inhibits the operation of the device, for example:

- opening window contact
- remote on/off
- infrared presence sensor
- enabling badge
- remote change of season

#### Function

*The contact is normally open.*

- ▶ when closing the CP contact, connected to a potential-free contact, the device switches to stand-by mode
- ▶ *CP appears on the display.*
- ▶ At the touch of a button on the display the symbol ⚠ flashes.

⊖ It is forbidden connect in parallel the CP input to one of another electronic board. Use separate contacts.







The CP presence contact can be configured for heating and cooling operation via the "To select digital input" [p. 35](#) settings menu item (digital input).



## 9.6 Functions

### 9.6.1 Basic menu

#### To access the basic menu

- ▶ with the display off, hold down  for 10 seconds  
*The device turns on and  appears*
- ▶ keep pressed until the indication  appears
- ▶ release the  key  
*The symbol  appears*

#### To navigate in the menu

- ▶ use the icons  

#### To select a menu item and to confirm the changes made

- ▶ press the icon   
*Confirming the change takes you to the next item.*

#### To exit the menu

- ▶ press the icon  for 10 seconds
- ▶ or wait 30 seconds the automatic shutdown

 After 30 seconds from the last action the control goes out and the settings is memorized.

### Menu items

**ot:** AIR probe offset (air probe setting)

**ur:** Value read by the R.H. sensor

**ut:** Probe Offset PT4

**uS:** Humidity setpoint

**ui:** Humidity hysteresis

**CF:** Scale





**ub:** Buzzer volume

**uu:** Not used

**uP:** Not used

### Set AIR probe offset

#### To set the air probe regulation

- ▶ select 
- ▶ press  to change settings
- ▶ increase or decrease the value with the icons  
- ▶ press  to confirm  
*By default it is set to 0.  
The setting range is from a minimum of -12.0 °C to a maximum of 12.0 °C.*





### 9.5.4 Bluetooth connection

The wall-mounted remote control can be connected via Bluetooth to one or more devices, for a maximum of 16. The devices must be equipped with an electronic board suitable for remote control.

### Set probe offset RH





 Modify only after real deviations from an actual measurement with professional instrumentation have been established.

#### To set the RH probe regulation

- ▶ select 
- ▶ press  to change settings
- ▶ increase or decrease the value with the icons  
- ▶ press  to confirm





### Set the humidity setpoint

#### To set the humidity setpoint

- ▶ select 
- ▶ press  to change settings
- ▶ increase or decrease the value with the icons  
- ▶ press  to confirm  
*The setting range is from 20.0% to 90.0%.*



### Setting the humidity hysteresis

#### To set the humidity hysteresis

- ▶ select 
- ▶ press  to change settings
- ▶ increase or decrease the value with the icons  
- ▶ press  to confirm  
*The setting range is from 1 (min) to 30 (max).*





### Scale

#### To change the temperature unit of measure

- ▶ select 
- ▶ press  to change settings
- ▶ select °C or °F
- ▶ press  to confirm  
*By default the temperature unit of measure is °C.*

## Adjusting buzzer volume

### To change the volume

- ▶ select 
- ▶ press  to change settings
- ▶ increase or decrease the value with the icons  
- ▶ press  to confirm  
*The volume setting range is from 00 (min) to 03 (max).*





 The volume changes after confirm the modification.

## 9.6.2 Advanced Menu

 **To access the Setup menu, it is necessary to access the Basic menu. See section "Basic menu" p. 53.**

The special functions menu can be accessed via the control panel.

### To access the setup menu

- ▶ from the basic menu press 
- Appears *
- ▶ press the  key once
- Appears *
- ▶ press  to confirm and log in  
*This takes you to the settings menu.*



### To navigate in the menu

- ▶ use the icons  

### To select a menu item and to confirm the changes made

- ▶ press  for 2 seconds  
*Confirming the change takes you to the next item.*

### To exit the menu

- ▶ press  for about 10 seconds  
*Appears *
- ▶ press  for about 10 seconds  
*The display turns off.*
- ▶ or wait 30 seconds after the last action  
*The display is switched off automatically.*

 After 30 seconds from the last action the control goes out and the settings is memorized.

## Menu items

**Ad:** Not used

**Pr:** Not used

**of:** Options for digital output

**rH:** Radiant heating options with R20

**rC:** Radiant cooling options with R20

**UC:** Not used

**Ac:** Anti-stratification in cooling



**Ah:** Anti-stratification in heating

**Ed:** Not used



**Fr:** Not used

## To select digital input

### To change the digital input

- ▶ select 
- ▶ press  to change settings
- ▶ select CP for contact presence (default)
- ▶ select CO to cooling open
- ▶ select CC to cooling close
- ▶ press  to confirm  
*By default digital input is set to CP.*

 For return to the default settings, set the digital input to "CP".

 By selecting one of the other inputs (CO,CC) the seasonality is locked. It is not possible to modify it through the key  of the control.

## Set radiant options in heating with R20

 To change the rH function, it is necessary to have the accessory MZS - Single zone module for radiant system, code EG1028II.

 To change the settings, please refer to the Instruction Sheet of the accessory MZS - Single zone module for radiant system, code EG1028II.







## Set radiant options to cooling with R20

 To change the rC function, it is necessary to have the accessory MZS - Single zone module for radiant system, code EG1028II.

 To change the settings, please refer to the Instruction Sheet of the accessory MZS - Single zone module for radiant system, code EG1028II.

## Set the anti-stratification function to cooling

### To set the anti-stratification function in cooling mode





- ▶ select 
- ▶ press  to change settings  
*Appears *
- ▶ press  to move within the menu
- ▶ select  to enable the function
- ▶ press  to confirm changes  
*By default, the anti-stratification function in cooling is set to .*

- ⚠ The anti-stratification function in cooling is to be set for appliances installed at low floor level equipped with an active air probe.

## Set the anti-stratification function in heating mode

### To set the anti-stratification function in heating mode

- ▶ select 
- ▶ press  to change settings  
*Appears *



- ▶ press  to move within the menu
- ▶ select  to enable the function
- ▶ press  to confirm changes  
*By default, the anti-stratification function in heating is set to .*

- ⚠ The anti-stratification function in heating is to be set for appliances installed high up on the wall or ceiling equipped with an active air sensor.

## 9.6.3 Pairing of control and unit

- ⚠ The matching procedure between command and device is mandatory.

### To pair the control with the unit

- ▶ with control switched on, at the same time press  and  for about 10 seconds  
*In the display area, where the setpoint is indicated, appears the number of connected devices. The displayed value flashes.*

1. Red LED
2. Green LED
3. Black button
4. Electrical box

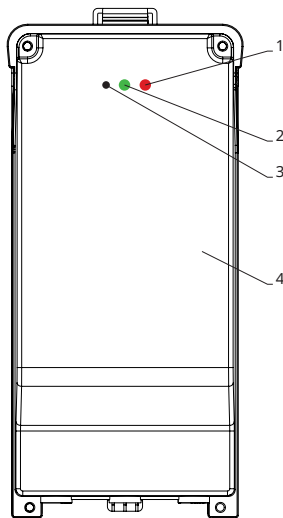

### On the electrical box on the unit

- ▶ press the black button for 3 seconds  
*The green LED flashes. The red LED is on.*
- ▶ wait for the procedure to complete  
*The green LED stops flashing.*





### On the wall mounted control panel

- ▶ *Appear the number assigned to the fancoil. Then appears the number of connected devices.*
- ▶ press  to exit the menu







## Reset pairing

- ⚠ To reset the pairing settings, it is first necessary to access the "Basic menu" [p. 53](#).



### To reset pairing settings

- ▶ access the basic menu
- ▶ press 
- ▶ press   
*All the way to the  menu.*
- ▶ press 







### To reset a single fancoil

- Appears *
- ▶ press 
  - ▶ *Appears *
  - ▶ press  to access the menu
  - ▶ use the  icons to move inside the menu  
*The assignment numbers assigned to the fancoils appear.*
  - ▶ select the fancoil to be reset
  - ▶ press  to confirm  
*-- appears, with an acoustic signal. The device is removed.*

### To exit the setting

- ▶ press  for 5 seconds  
*Exit the  setting. Back to menu 02.*

### To reset all fancoils

- Appears *
- ▶ press  until  appears  
*Appears *
  - ▶ press  to access the menu
  - ▶ use the  icons to move inside the menu
  - ▶ select No to maintain all fancoils
  - ▶ select Yes to reset the fancoils
  - ▶ press  to confirm

## LED interface operation on the electrical box

### If the device is being paired

*The green LED flashes.*

### If the device is paired and functioning

*The green LED is on.*

### If the device has not been paired and is not functional

*The green LED is off.  
The red LED is on.*

**If the device is in alarm status**

The red LED flashes.

⚠ The red LED flashes according to the type of alarm. To check the alarm type, please refer to the following "Error signals" p. 56 section.

**If communication with the board is missing**

The green and red LEDs will flash once every second.

**9.6.4 Error signals**

The PCB has a status LED.

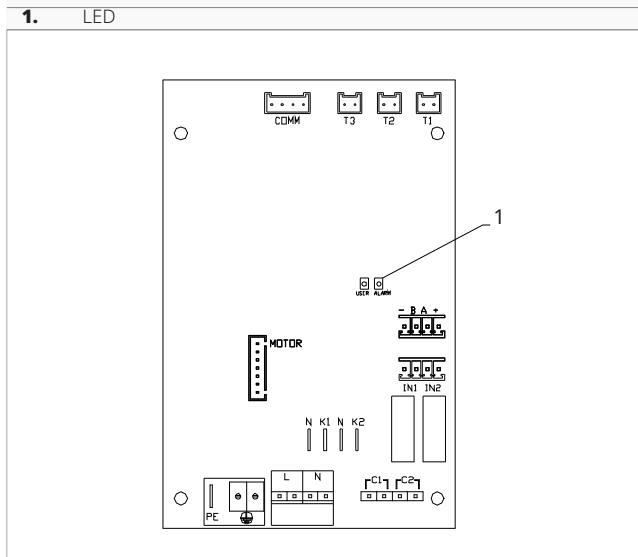

⚠ Once the pairing has been completed, the red LED on the cover of the electrical box performs the same functions as the LED on the board on the unit.

⚠ The flashing LED indicates errors.

⚠ With the LED on, it is indicated that there aren't errors.

**LED signals**

- ▶ Led flashing  
*Errors to be shown on the display.*
- ▶ LED off  
*Remote control switched off.*
- ▶ LED on  
*Wall control panel on and no alarm.*
- ▶ LED continuous flashing with pause between flashes  
*Unsuitable water temperature alarm.*
- ▶ LED 2 flashes / pause  
*Internal fan motor alarm faulty or disconnected.*
- ▶ LED 3 flashes / pause  
*Alarm for water temperature probe H2/T2 disconnected or faulty.*
- ▶ LED 6 flashes / pause  
*Communication error alarm with wall control panel.*

**9.6.5 Visualization of alarms on display**

⚠ In the event of an alarm, the device still maintains active functions.

⚠ The symbol ⚠ is displayed to indicate alarms on the wall control panel.

⚠ To access the Setup menu, it is necessary to access the Basic menu. See section "Basic menu" p. 53.

**To visualise errors on the wall control panel**

- ▶ access the basic menu
- ▶ press **A**  
*Appears*
- ▶ Press **+**  
*until you reach the menu*
- ▶ press to confirm  
*Appears*
- ▶ press to access the menu  
*Then the number assigned to the fancoil appears and then the error is displayed.*

**Displayed alarms**

- ▶ E2 Faulty internal fan motor or disconnected  
*None of the modes can be activated.*
- ▶ E3 Water temperature probe H2/T2 disconnected or failure  
*None of the modes can be activated.*
- ▶ E6 Incorrect water temperature with automatic season function setting  
*The fancoil is performing heating and cooling functions incorrectly. None of the unit's functions can be activated.*
- ▶ E7 Module Communication Alarm  
*Bluetooth communication not functioning.*
- ▶ E8 Communication error  
*Communication error between the wall control panel and the fan coil. (pairing between control and device mandatory)*
- ▶ h2o Incorrect water temperature  
*In heating mode, the water temperature is below 30 °C.*
- ▶ In cooling mode, the water temperature is above 20 °C.

⚠ Errors E7 and E8 are displayed without the error display procedure on the wall control panel.

⚠ Alarm E7 is an error that only appears with the control panel for wall control with Bluetooth connection (Code EGB749II).

## ONBOARD ELECTRONIC BOARD B4V042 + WALL CONTROL B3V151

### 10.1 Onboard electronic board Code B4V042 + wall control Code B3V151

#### 10.1.1 Interface

Wall mounted control with thermostat, summer/winter and speed selectors.

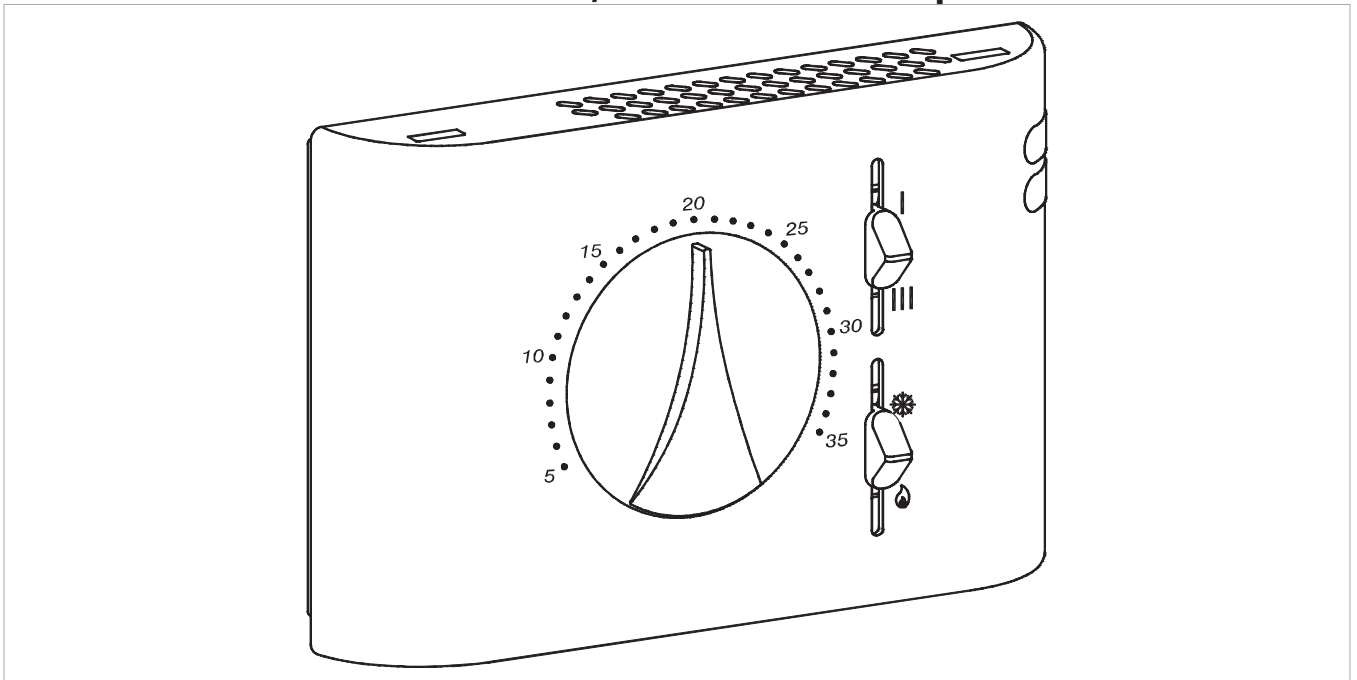

#### 10.1.2 Description

Wall mounted control with thermostat, summer/winter and speed selectors, in connection with B4V042.

**⚠ For 2 pipe units**

### 10.1.3 Connection diagram

<b>L-N</b>	230 V/50 Hz electrical power supply connection
<b>EV</b>	Solenoid valve permission input
<b>V1</b>	Maximum fan speed
<b>V2</b>	Medium fan speed
<b>V3</b>	Minimum fan speed

<b>V4</b>	Supersilent speed
<b>Y1</b>	Water solenoid valve (230 V / 50 Hz / 1 A power output)
<b>M1</b>	Fan motor DC Inverter
<b>H2</b>	Hot water temperature probe 10 kΩ

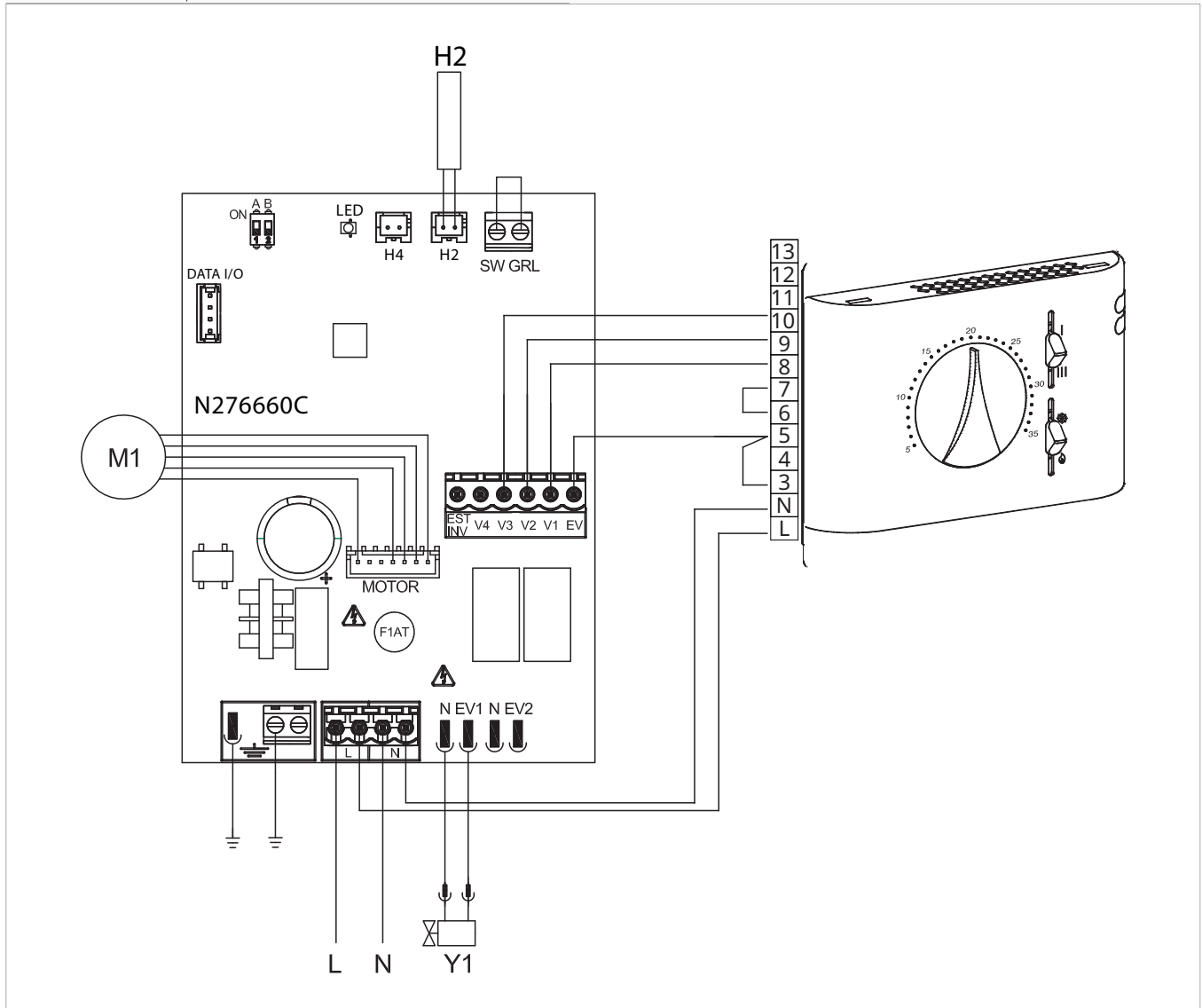

### 10.1.4 Connection diagram with seasonal switching

<b>L-N</b>	230 V/50 Hz electrical power supply connection
<b>EV</b>	Solenoid valve permission input
<b>V1</b>	Maximum fan speed
<b>V2</b>	Medium fan speed
<b>V3</b>	Velocità minima ventilatore

<b>V4</b>	Supersilent speed
<b>Y1</b>	Water solenoid valve (230 V / 50 Hz / 1 A power output)
<b>M1</b>	Fan motor DC Inverter
<b>KE</b>	Auxiliary relay (not included in supply)
<b>H2</b>	Hot water temperature probe 10 kΩ

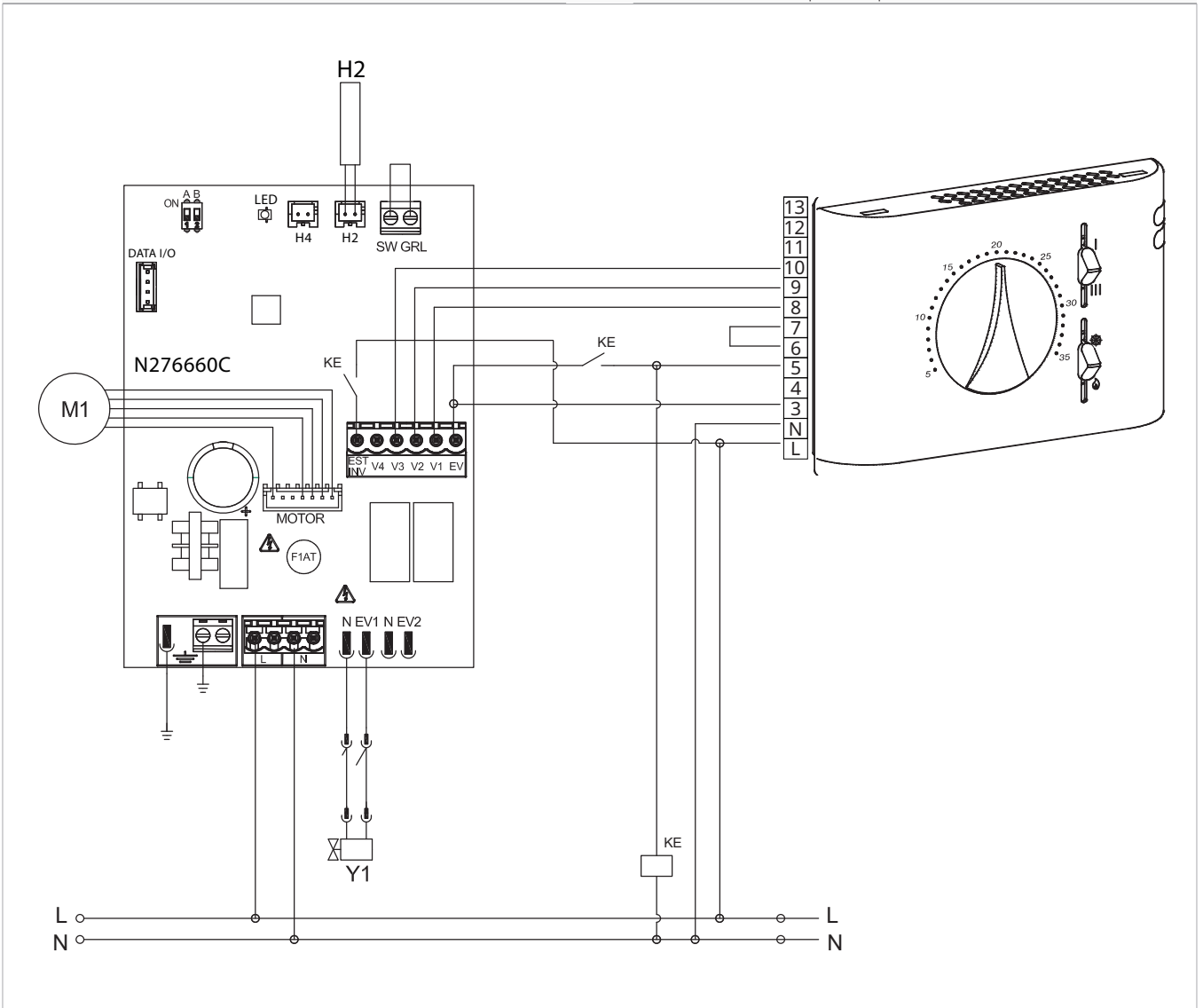

### 10.1.5 Generic thermostat connection diagram

<b>L-N</b>	230 V/50 Hz electrical power supply connection
<b>EV</b>	Solenoid valve permission input
<b>V1</b>	Maximum fan speed
<b>V2</b>	Medium fan speed
<b>V3</b>	Minimum fan speed
<b>V4</b>	Supersilent speed
<b>E</b>	Input selection heating/cooling
<b>Y1</b>	Water solenoid valve (230 V / 50 Hz / 1 A power output)

<b>UV</b>	UV lamp accessory connection
<b>M1</b>	Fan motor DC Inverter
<b>TA</b>	3 speed room thermostat (to buy, install and connect by the installer)
<b>CV</b>	Thermostat consent
<b>SV</b>	Speed selector
<b>H2</b>	Hot water temperature probe 10 kΩ

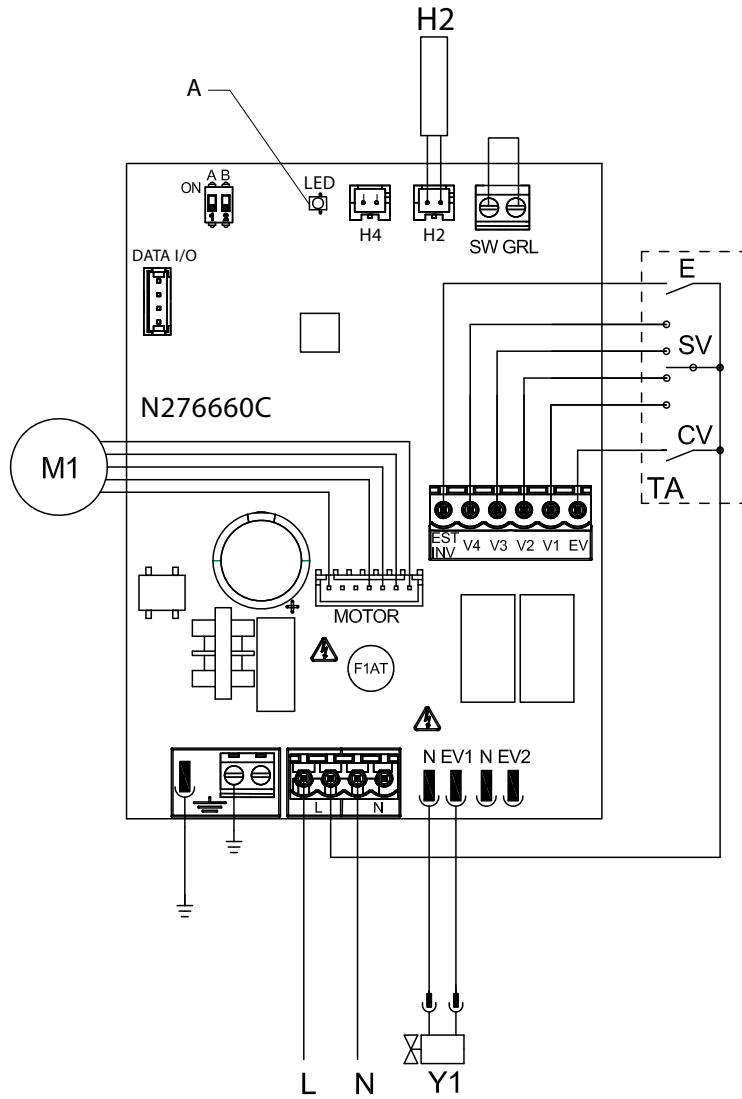



## 10.2 Connections

### 10.2.1 Connection with 3 speed thermostats

#### CV input

The CV input is the ON/OFF of the board.

- in case of open input, the circuit board goes into stand-by mode
- in case of closed input, the circuit board is in operation

⚠ Please refer to the sections of the electrical diagrams for connection indications.

#### To activate solenoid valve Y1

- ▶ Connect the CV input to the terminal L of the 230 V power supply

#### Speed inputs V1, V2, V3, V4

Inputs V1, V2, V3, V4 regulate the ventilation speed.

The printed circuit board has 4 speed inputs:

- V1 maximum speed (1500 rpm)
- V2 - medium speed (1100 rpm)
- V3 - minimum speed (680 rpm)
- V4 supersilent speed (550 rpm)

⚠ Connect the 3 speeds of the thermostat to three of the four available inputs based on the characteristics and use of the location.

Examples:

- to residential application where maximum silence is required, connect V2, V3 e V4
- for a residential application where heating capacity is a priority, connect V1, V2, V3

In the event of simultaneous closure of several inputs, the motor will run at a number of revolutions equal to that set by the connection with the highest speed.

⚠ You can connect several boards in parallel to a single thermostat, even using different speed.

### 10.2.2 Water probe management

Through the water temperature probe (10 kΩ) positioned in the compartment on the unit's coil, the functions can be regulated:

- minimum temperature in heating mode (30 °C)
- maximum temperature in cooling mode (20 °C)

#### Water probe connection to the control

**In case of combination with electromechanical thermostats, or other commercial controls**

- ▶ the H2 water probe must not be connected to the circuit board on the appliance

**The printed circuit board works in:**

- minimum water temperature for heating function (<30 °C)
- maximum water temperature for cooling function (>20 °C)

⚠ If the printed circuit board detects the water temperature probe correctly, start-up takes place under normal conditions.

In case of temperature not suitable for active operation:

- the ventilation stops
- error is indicated by the flashing of the LED on the PCB

#### Operating mode Heating/cooling

The Heating/Cooling operation mode is activated through the EST-INV input on the printed circuit board:

- when the connection is open, heating operation is activated
- when the connection is closed, Cooling operation is activated

⚠ It is possible to use the device without the water probe activated. In this case the error is signaled on led.

⚠ Please refer to "Error signals" [p. 61](#) for LED indications.

#### To confirm operation without probe

- ▶ disconnect and connect the board power  
*This condition will be saved by the board for all subsequent starts.*
- ▶ reconnect the probe to resume normal operation

## 10.3 Error signals

#### LED signals

- ▶ LED off  
*The CV contact is open, stand-by condition.*
- ▶ LED on  
*The CV contact is closed, normal operation.*
- ▶ LED 1 flash / pause  
*Water temperature probe H2 alarm not suitable, temporary stop of the ventilation until the temperature reaches an appropriate value.*
- ▶ LED 2 flashes / pause  
*Motor alarm (for example jamming due to foreign bodies or fault in the rotation sensor).*
- ▶ LED 3 flashes / pause  
*Water probe alarm disconnected or faulty.*

## 0-10 V CONNECTION CODE B10042

### Installation

#### Description

Onboard electronic board for control from systems with analog 0-10V output.  
 Mounted onboard, it allows motor speed control in modulation mode.

Motor regulation can be made through a 0-10 V analogue input with an input impedance of 25 kΩ.

**⚠** Consider the impedance value, especially when controlling several units in parallel.  
 It has a 230 V output for controlling a solenoid valve.

### 11.1 Connection diagram

<b>M1</b>	Fan motor DC Inverter
<b>PE</b>	Earth connection
<b>L-N</b>	Power supply connection 230 V / 50 Hz / 1 A
<b>Y1</b>	Water electrovalve (voltage output 230 V / 50 Hz / 1 A)

<b>10V</b>	Input 0-10 V
<b>F10</b>	Electronic board on the machine
<b>A</b>	Led

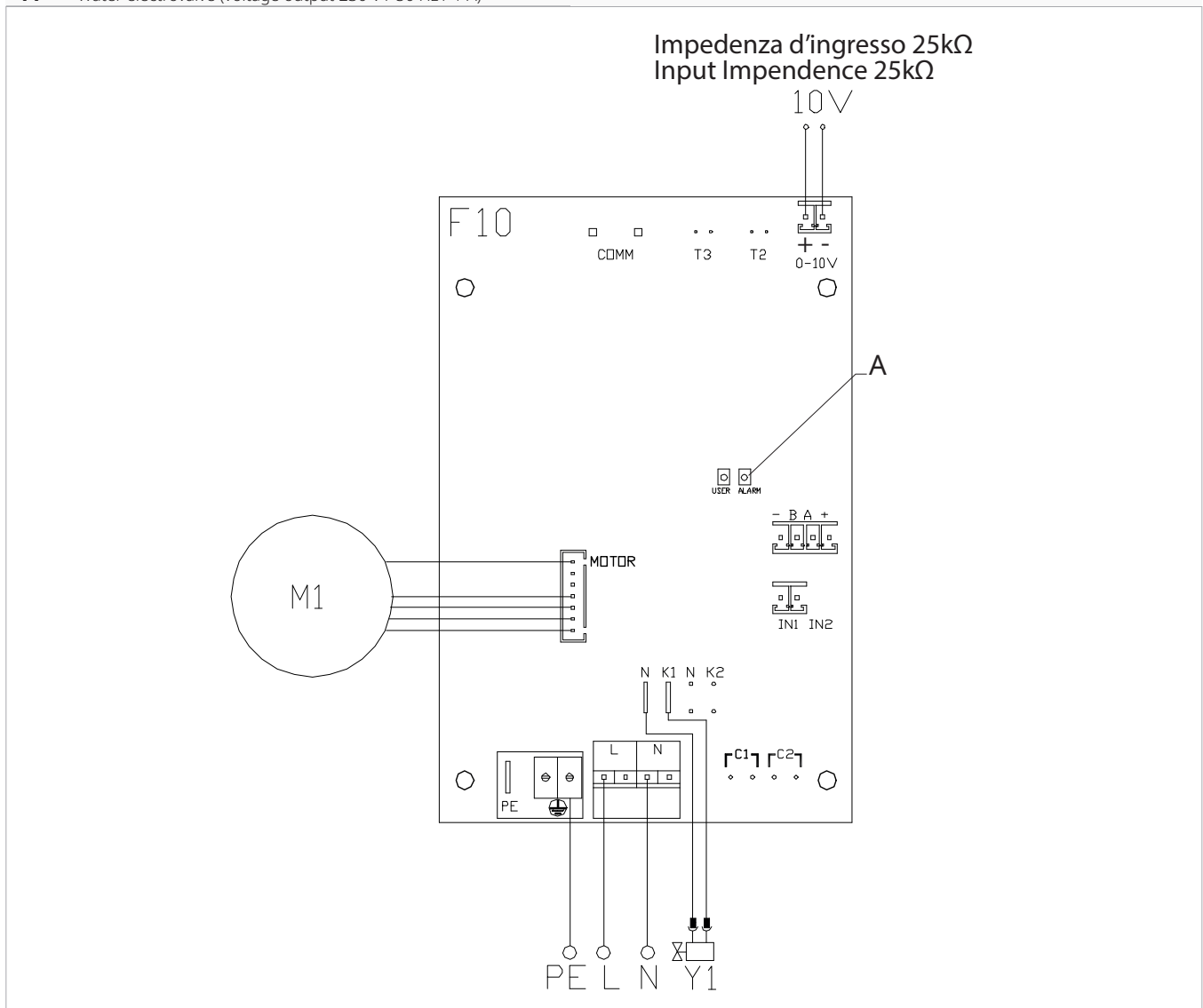

## 11.2 Connections with 0-10 V thermostats

### The 10 V input

- activates solenoid valve Y1
- regulates the fan speed

Linear speed regulation is possible, from a minimum value (400 rpm) to a maximum value (1500 rpm) for voltage values  $\geq 1.1$  V to 10 V DC.

- ⚠ The motor is switched off for values below 1 V.
- ⚠ The Y1 solenoid valve is switched on for voltage values greater than 1 V. The Y1 solenoid valve is switched off at values below 0.9 V.

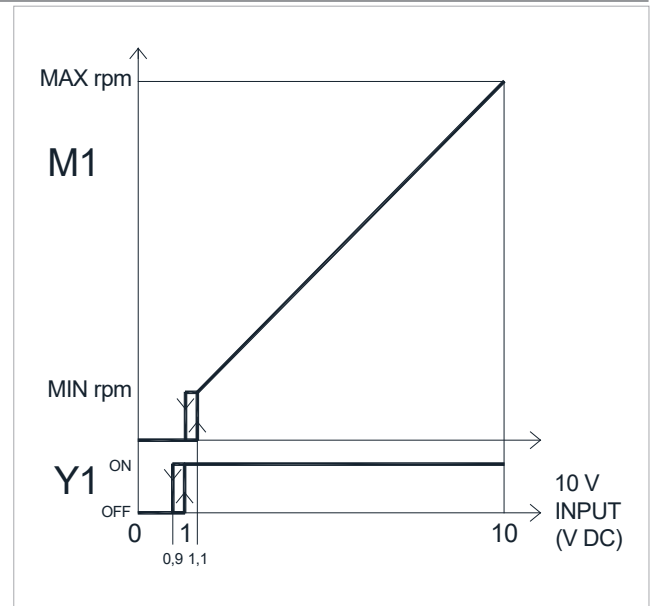

## 11.3 LED signal

The PCB has a status LED.

### LED signals

- ▶ LED off  
*Input signal below 0.9 V. Device switched off or without power supply.*
- ▶ LED on  
*Input signal more than 1 V. Normal operation of the device.*
- ▶ LED frequent flashing  
*Activation of grille safety microswitch S1, dovuto all'operazione di pulizia filtri.*
- ▶ LED 2 flashes / pause  
*Motor alarm (for example jamming due to foreign bodies or fault in the rotation sensor).*



**innova**

INNOVA S.r.l.  
Via I Maggio 8 - 38089 Storo (TN) - ITALY  
tel. +39.0465.670104 - fax +39.0465.674965  
info@innovaenergie.com